

# Zappos

*6pm*

## Vendor Guide

2026 Version

# Zappos

Dear Vendors,

Here at Zappos our culture is based around our core values, and building collaborative relationships with our Vendors.

Our purpose is this; to inspire the world by showing it's possible to simultaneously deliver happiness to customers, employees, community, and Vendors in a long-term, sustainable way.

One of our main goals is to improve the customer experience. We know that we cannot do this alone, and we look to our Vendors to partner with us to make every customer's experience a positive one.

This document establishes guidelines that will accelerate the movement of merchandise from our Vendors to the customer, and cultivate those positive customer experiences. This guide will clarify how we can achieve this goal together.

This guide applies to all Vendors selling their merchandise through the Zappos.com and 6pm.com sales channels. For ease of reference, all channels are referred to as "Zappos" throughout the guide, but will only apply to the sales channel that the Vendor chooses during set up.

We look forward to partnering with you and your teams to achieve our goals of providing the best customer and Vendor experience possible.

Thank you,  
Zappos Vendor Support

# TABLE OF CONTENTS:

<b>Section 1: Introduction</b>	<b>4-5</b>
Vendor Checklist	5
<b>Section 2: Electronic Data Interchange (EDI)</b>	<b>6-11</b>
Fulfillment Center Address List	6
EDI Business Rules	7-9
GS1-128 Shipping Label	9-11
<b>Section 3: Fulfillment of a Purchase Order</b>	<b>12</b>
<b>Section 4: Imagery</b>	<b>13</b>
<b>Section 5: Product Labeling</b>	<b>14-15</b>
<b>Section 6: Packaging Guidelines</b>	<b>16-23</b>
Packaging and Shipping Requirements	17-19
Footwear and Apparel Packaging Recommendations	20
Watch and Jewelry Guidelines	21
Liquid, Sharp, Fragile, or Damage Prone Items	22-23
<b>Section 7: Proposition 65</b>	<b>24</b>
<b>Section 8: PFAS (Per- and Polyfluoroalkyl Substances)</b>	<b>24</b>
<b>Section 9: Shipping Carton Information</b>	<b>24-25</b>
<b>Section 10: Zappos Routing Request Portal</b>	<b>26</b>
<b>Section 11: Zappos Paid Freight</b>	<b>27-29</b>
Standard Bill of Lading	28
Master Bill of Lading	29
<b>Section 12: Vendor Paid Freight (Prepaid/Direct Delivery)</b>	<b>29-30</b>
<b>Section 13: Pallet Requirements</b>	<b>31-32</b>
<b>Section 14: Loading Requirements</b>	<b>32-33</b>
<b>Section 15: International Shipments</b>	<b>34</b>
<b>Section 16: Vendor Compliance &amp; Scorecard</b>	<b>35</b>
<b>Section 17: Zappos Vendor Returns / Inventory Removals</b>	<b>36</b>
<b>Section 18: Accounts Payable</b>	<b>37</b>
<b>Appendix: Summary of Major Changes</b>	<b>38</b>
<b>Routing Request Portal Instructions</b>	<b>39-52</b>
Zappos Vendor Guide (Revised 05/2026).	

## SECTION 1: Introduction

This guide provides policies for Electronic Data Interchange (EDI), Purchase Orders (POs), packaging, labeling, shipping, invoicing and returns for purchases made by Zappos. Read this guide in its entirety before shipping product to the Fulfillment Center (FC) designated on the PO.

To ensure that Vendors have the latest version of this guide, a current version can be found on our Vendor Resources Website: [www.zappos.com/vendorresources/](http://www.zappos.com/vendorresources/) or you can request a copy from the Vendor Support Team.

If you have any questions or cannot comply with any part of this guide, do not accept our Purchase Order and do not ship. Instead, contact the Zappos buyer who owns the PO immediately to discuss.

Need assistance with...	Email the following team...
Vendor Guide specifics, packaging & labeling questions, Zappos Purchase Order System access and questions regarding the Vendor Scorecard.	<a href="mailto:zappos-vendorsupport@amazon.com">zappos-vendorsupport@amazon.com</a>
Routing questions, 3rd party carriers, Routing Portal access and Routing Portal issues.	<a href="mailto:zappos-traffic@amazon.com">zappos-traffic@amazon.com</a>
EDI messaging, EDI setup and testing concerns.	<a href="mailto:zappos-edi@amazon.com">zappos-edi@amazon.com</a>
Invoicing concerns and Accounts Payable portal access (Taulia).	<a href="mailto:zappos-apetail@amazon.com">zappos-apetail@amazon.com</a>

**MERCHANDISE DELIVERIES MAY BE AUDITED TO ENSURE GUIDELINES ARE BEING MET.**

**DEVIATION FROM ANY PART OF THE ZAPPOS VENDOR GUIDE MAY RESULT IN CHARGEBACKS OR THE REFUSAL AND/OR RETURN OF SHIPMENTS AT THE VENDOR'S EXPENSE.**

**THE FULFILLMENT CENTER (FC) MAY REFUSE AND RETURN, AT THE VENDOR'S EXPENSE, SHIPMENTS THAT DO NOT COMPLY WITH LAWS AND REGULATIONS INCLUDING, WITHOUT LIMITATION, THE CONSUMER PRODUCT SAFETY IMPROVEMENT ACT.**

## **Vendor Checklist**

The below checklist is intended to be a high-level summary of compliance requirements which will allow Vendor shipments to move quickly and accurately through our supply chain. Please refer to the complete Vendor Guide for all of our requirements.

### **✔ Electronic Data Interchange (EDI)**

All Vendors must be EDI compliant. Zappos requires the following transaction sets.

- a. 810 – Invoice
- b. 850 – Purchase Order
- c. 860 – Purchase Order Change
- d. 856 – Advance Shipment Notice – ASN (including SSCC-18 information)
- e. GS1—128 Shipping Label
- f. 997—Functional Acknowledgement

### **✔ Product Labeling & Packaging**

- UPC/EAN Barcodes - UPC and EAN (GTIN/GLN) barcodes must be GS1 Certified when conducting business with Zappos. Products with uncertified UPC/EANs cannot be accepted into the FC.
- For all product types packaged in poly bags, a UPC/EAN hangtag or label must be attached to the product AND must be placed on the outside of the individual product box, poly bag, or cardboard box even though a hangtag or label is already provided on the product.
- Poly bags must be clear and transparent and completely sealed on all products.
- Vendors must comply with all applicable federal, state and local laws, rules, regulations, ordinances and directives with respect to product packaging materials.
- All products must be packaged and ready to ship to the customer without any additional packaging or prep required by Zappos. Zappos cannot accommodate for any prep when items arrive at our FC.

### **✔ Routing**

All shipments must be approved by the Inbound Transportation Services team prior to the Vendor or their agents tendering freight to any carrier. This includes UPS and other small parcel carriers as well as Vendor paid shipments.

- A shipment is not approved to ship until a dispatch number has been assigned to the Routing Request. This number is required on the EDI-856(ASN).

### **✔ Shipping**

- Vendors will receive instructions via e-mail from our Inbound Transportation Services team advising whether the shipment is approved to ship via small package carrier, Less-Than-Truckload (LTL) or Truckload (TL).
- All cartons must comply with all federal, state and local carrier HAZMAT laws, regulations and guidelines.

## SECTION 2: Electronic Data Interchange (EDI)

All Vendors are required to use EDI, comply with the EDI requirements, and testing contained herein.

**Transaction Sets:** Zappos requires the following transaction sets. EDI documents, guidelines, and mappings can be found on our [Vendor Resources](#) site.

- a. 810 – Invoice
- b. 850 – Purchase Order
- c. 860 – Purchase Order Change
- d. 856 – Advance Shipment Notice—ASN (including SSCC-18 information)
- e. GS1-128 Shipping Label
- f. 997 – Functional Acknowledgement
- g. 855 – Purchase Order Acknowledgment (Optional)

### EDI Setup, Testing Certification and Implementation:

- a. Zappos will initiate all EDI setups and EDI testing for new Vendors. Please consult with your Zappos buyer to begin testing with Zappos.
- b. **Prior to receiving any orders, the EDI testing and certification process must be completed.**
- c. Zappos uses Inovis as our VAN, and ZZ/ZAPPOSKY as our Qualifier/ISA ID for production.
- d. For all setup, migration, or mappings changes: We will request the Vendor’s VAN, ISA ID, Qualifier, and EDI contact information so we can setup the trading partnership.

For all inquiries regarding EDI please email [zappos-edi@amazon.com](mailto:zappos-edi@amazon.com).

### Fulfillment Center (FC) Address List:

FC Code	EDI ID Code(N104)	Address 1	Address 2
SDF4	0001	c/o Amazon.com Services Inc.	376 Amazon.com Blvd, Shepherdsville, KY 40165
SDF8	0003	c/o Amazon.com INDC LLC	900 Patrol Road, Jeffersonville, IN 47130
IND4	0008	c/o Amazon.com Services Inc.	710 S. Girl School Road, Indianapolis, IN 46231
ZAP1	0018	c/o Zappos.com Studio	101 S. Baldwin Street, Madison, WI 53703
ABE2	0024	c/o Amazon.com PADC LL	705 Boulder Drive, Breinigsville, PA 18031
PHX3	0025	c/o Amazon.com AZDC LCC	6835 West Buckeye Road, Phoenix, AZ 85043
PSC2	0038	c/o Amazon.com Services Inc.	1351 S. Road 40 E, Pasco, WA 99301
PPO4	0039	c/o Amazon.com Services Inc.	9850 Mississippi Street, Crown Point, IN 46307
ABQ2	0040	c/o Amazon.com Services Inc.	6251 Pioneer Trail NW, Los Lunas, NM 87031
POC3	0041	c/o Amazon.com Services Inc.	6120 Clinker Drive, Jurupa Valley, CA 92509
RYY2	0042	c/o Amazon.com Services Inc.	1250 Cassville White Road, White, GA 30184
HEA2	0043	c/o Amazon.com Services Inc.	650 Boulder Dr, Breinigsville, PA 18031

## EDI Business Rules:

EDI Message	EDI Document Name	Business Rules
850	Purchase Order (PO)	<b>Paper and email orders are not valid and cannot be accepted.</b>
		To prevent confusion and duplicate shipments, POs will only be sent once and will not be re-sent. Zappos 860s will be used to communicate <b>ALL</b> PO changes.
		The PO number can contain up to twenty-two (22) alphanumeric characters.
		The Vendor ID number is included on the REF02 segment where REF=VR within the PO. The Vendor ID number is used to uniquely identify individual suppliers in the Zappos system. This number is assigned by Zappos and required on the ASN and Invoice.
860	PO Change (PC)	860s communicate Zappos Buyer-initiated changes or changes requested by the Vendor that have been approved by the Zappos Buyer.
		Shipments must be sent to the address included on the 850 or 860.
		Shipping address change requests may be communicated by Zappos 30 days prior to the ship date.
856	Advance Ship Notice—ASN (SH)	The ASN should be sent within 2 hours of the shipment leaving the Vendor's dock.
		The ASN does <u>not</u> replace the Routing Request process. For each PO, a Routing Request must be submitted, approved, and receive a dispatch number from Zappos. Refer to 27 for the Routing Request process.
		When the ASN's REF01 code is BX, the REF02 should contain the dispatch number provided by the Zappos Inbound Transportation Services team. This number is dynamic and required for all shipments. If the dispatch number is incorrect it will fail in our system.
		Only one ASN should be used for the entire shipment. Do not send multiple ASNs for one single shipment.
		Indicate either small parcel shipment <u>or</u> LTL/TL shipments as the carrier type. Only one carrier type should be used.
		When a small parcel carrier is used, the lead tracking number should be included in the REF02, and the individual carton numbers should be used in each corresponding MAN05.

EDI Message	EDI Document Name	Business Rules
855	PO Acknowledgement or Change Request (PR) [Optional]	<p>Only one shipment per PO. If an item is not available for shipment within the requested shipping window, notate "AC" (Acknowledge - With Detail and Change) on the BAC02 segment and pick one of the two options below:</p> <ol style="list-style-type: none"> <li>1. Request a date change for the entire order by updating the new start ship date information in the DTM segment.</li> <li>2. Request to cancel the item that is not available from the current order, notating the item's appropriate status code on the ACK01, and contact your Zappos Buyer to request a separate PO for the item.</li> </ol> <p>If an unforeseen circumstance causes the need to update the Purchase Order after the original 855, a second 855 should be sent at least <b>seven (7) business days</b> before the Start Ship Date. The exception to a second 855 is if a Zappos 860 change contains order information that a Vendor cannot fulfill.</p> <p>An 855 (in response to an 860) is not expected if an 855 has already been received by Zappos. The exception is if a Vendor cannot meet any part of the change request.</p> <p>For example:</p> <ul style="list-style-type: none"> <li>- A Zappos 860 requests to add units that cannot be shipped. At this point, an 855 can be sent indicating the change was rejected - ACK01 = IR.</li> <li>- A Zappos 860 requests to add 100 units, but only 60 units are available to ship. At this point, an 855 can be sent indicating a quantity change from 100 units to 60 units - ACK01 = IQ.</li> <li>- A Zappos 860 is received for a UPC/EAN change and it is incorrect. At this point, an 855 can be sent indicating the UPC/EAN is invalid - ACK01 = R2. If the Vendor style or UPC/EAN is incorrect, then use ACK01 = R2 and provide the correct number in the PO107 segment.</li> </ul>
810	Invoice (IN)	<p>Invoices should be sent within 2 hours of the shipment leaving the Vendor's dock. Zappos expects to receive the ASN and the Invoice at the same time.</p> <p>The Vendor ID number must be included on the REF02 segment of the invoice and it must match the Vendor ID received on the PO.</p> <p>Each UPC/EAN should only be used <u>one</u> time on each invoice.</p> <p>Invoice numbers must be unique to the 810 transmission. 810s containing an invoice number that has been previously received by Zappos will fail to process.</p> <p>When the Invoice is transmitted, the UPCs on the Invoice must match the UPCs on the PO. Any additional UPCs included on the Invoice will delay payment, pending the Buyer's review.</p>
997	Functional Acknowledgement (FA)	<p>Zappos sends a rejected 997 message for document failures. Failed documents are <u>not</u> processed through our system.</p> <p>In addition to sending a rejected 997, Zappos will email the Vendor's EDI Contact (as listed in the Zappos system) an Error Notification. It includes specific details regarding the EDI failure and re-transmittal request. The EDI Contact should review these notifications right away as all EDI transactions are time sensitive.</p> <p>The EDI Contact must be capable of correcting and resending EDI messages.</p>

EDI Message	EDI Document Name	Business Rules
GS1-128	Shipping Label (Carton Label)	The 856 carton level detail should match the items inside the carton. A SSCC-18 barcode needs to be used for each carton and must match the 856 (MAN02).
		Each carton should only have one GS1-128 label - no other barcodes (besides the PO#, SSCC-18, and Zip Code) should be included on the carton.
		The label must include both the human-readable <u>and</u> barcoded PO number format.
		The label must specify the product type that was included in the PO on the REF02 segment.
		Inaccuracies or missing labels will result in a delay of receipt of product and/or payment.
		<b>The label must include all mandatory fields. See sample of the SSCC-18/GS1-128 Carton Label shown on pages 9-11.</b>
		The readable and barcoded portion of the PO barcode (in Zone E) should only scan and read the PO number. Any application identifiers should be encoded in the barcode symbology per GS1 standards.
		All quiet zones (blank area or margin on either end of a lineal barcode) on the label should be at least .25".

## STANDARD GS1-128 LABEL

**4" wide x 6" high**

### Barcode requirements:

Symbology Code = GS1-128

X Dimension = 15-20 MLS

Density=3.690 CHAR/ins. A

Height = 1.063 inches

<b>FROM:</b> ABC Company 1234 Distribution 9876 Lucky Star Ave. San Francisco, CA 94111	<b>TO:</b> Zappos.com LLC c/o Amazon Services LLC 376 Zappos.com Blvd. Shepherdsville, KY 40165
<b>To Zip Code:</b> (420) 40165 	<b>Carrier:</b> See Carton Label Notes  Ship Date: 07072025 UNIT (ITEM) QTY: 12 BOX: 1 of 1
<b>PO: EXNULAO8043793</b> 	
<b>Description:</b> MIXED BOX <b>Style:</b> AI50 <b>Size:</b> 8.5 <b>Color:</b> BLKIT	<b>UPC:</b> 123456789012 <b>Product Type:</b> Footwear <b>Item Description:</b> Narrow
<b>SSCC-18</b> (00) 0 0655024 000197917 8 	

# GS1-128 Label - Zone Requirements

Zone A	<b>Ship From:</b> Ship From Name Address 1 Address 2 City, State Postal Code	<b>Ship To:</b> Ship To Name Ship to Alternate Name Address 1 Address 2 City, State Postal Code	Zone B
Zone C	<b>To Zip Code:</b> (420) 40165 	<b>Carrier:</b> <b>Ship Date:</b> <b>Tracking #:</b> <b>Unit (Item) Qty:</b> <b>Box:</b> 1 of XXXX	Zone D
Zone E	<b>PO:</b> ZQTVBD8043793 		
Zone G	<b>Description:</b> <b>Vendor Item #:</b> <b>Size:</b> <b>Color:</b>	<b>UPC:</b> <b>Product Type:</b> Footwear <b>Item Description:</b> Narrow	Zone H
Zone I	Serialized Shipping Container Code 		

Zone	Content: <b>FIELDS IN BLUE ARE OPTIONAL</b>	Font size
A	Vendors Ship From name and address	10 to 12 pt font
B	Ship To name and address. Note: All address fields from the Purchase Order ship to address, including the N201 additional address name, are required.	10 to 12 pt font
C	Ship To postal code and barcode	10 to 16 pt font
D	Shipment Information: Carrier, B/L # or Tracking #, Ship Date, Unit (Item) Quantity, Carton Tally information (Box xx of yyy)	10 to 16 pt font
E	PO Number (Human-readable format) PO Number barcode	10 to 16 pt font
G	Description, Vendor Item #, Size, Color	10 to 16 pt font
H	UPC, Item Description, Product Type: Where REF01 = "PRT" from the Purchase Order, this is a Zappos provided value that uniquely identifies each Product Type as defined by Zappos. Valid codes are: FW - Footwear      AP - Apparel      AC - Accessories      EL - Electronics HW -Housewares    PC - Personal Care    BL - Bags or Luggage    PG - Pet Gear EY - Eyewear      JE - Jewelry      HA - Hats      BE - Beauty CL - Clothing      BS - Baby Shop      HO - Hosiery	10 to 16 pt font
I	GS1-128 Serial Shipping Container Code (SSCC-18)	10 to 16 pt font

SSCC-18/GS1-128 Carton Label Notes  
 Actual Size = 4" X 6" \*Illustration not to scale\*  
**(856 Advance Shipment Notice—EDI Equivalent)**

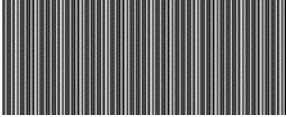
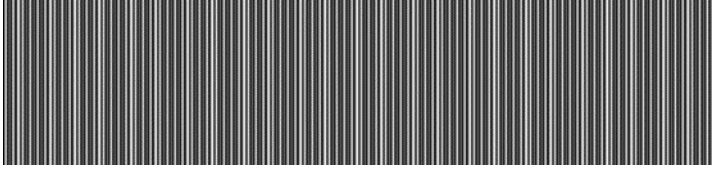
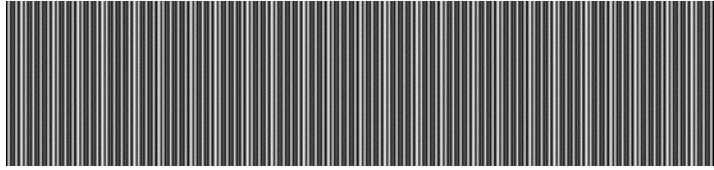
Zone A	<b>Ship From:</b> N102 (N101 = SF) N301 (N101 = SF) N302 (N101 = SF) N401, N402 N403 (N101 = SF)	<b>Ship To:</b> N102 (N101 = ST) N201 (N101 = ST) N301 (N101 = ST) N302 (N101 = ST) N401, N402 N403 (N101 = ST)	Zone B
Zone C	<b>To Zip Code:</b> (420) N403 (N101 = ST) 	<b>Carrier:</b> TD505 or TD503 (TD502 = 2) <b>Ship Date:</b> DTM02 (DTM01 = 011)  <b>Unit Qty:</b> $\sum$ of SN102 in HL*n*I <b>Box:</b> 1 of XXXX	Zone D
Zone E	<b>PO: ZQTVBD8043793</b> 		
Zone G	<b>Description:</b> PID05 (PID02 = "08") or Mixed <b>Vendor style #:</b> LIN05/07/09/11 (VA) <b>Size:</b> LIN05/07/09/11 (IZ) <b>Color:</b> LIN05/07/09/11 (VE)	<b>UPC:</b> LIN03 (LIN02 = EN or UP) <b>Product Type:</b> Description of REF02 (REF01 = PRT) or REF02 code <b>Item Description:</b> PID05 (PID02 = 91)	Zone H
Zone I	<b>MAN02 (MAN01 = GM)</b> 		

## SECTION 3: Fulfillment of a Purchase Order

**Acceptance of Purchase Orders:** Failure to confirm or respond to a Purchase Order within **two business days** shall constitute the Vendor's acceptance of the order. We assume no liability for costs the Vendor incurs or shipments they make prior to the receipt of a valid PO and the acceptance of that PO.

**Unshipped Items:** Unshipped portions of an order should not be shipped and cannot be received when the PO is in a "Closed", "Canceled", "Concluded" or "Voided" status in the Zappos Order Portal, Zapporo.

**Cancellations:** We may cancel any PO by providing the Vendor with an electronic (such as e-mail or EDI) written notice of the cancellation beginning 30 days prior to the Start Ship Date.

**Replacements, Substitutes, & Overages:** Do not substitute or change a product in a shipment provided in a PO without sending the appropriate EDI-855 PO change request document. Zappos does not accept substitutions or replacement products. Shipped products that were never ordered are subject to being returned at the Vendor's expense or may result in disposal. This includes any additional quantities or overages that are not listed on the PO. In the case of disposal or liquidation, Zappos will not pay Vendors for the unordered product.

**Fill Rate:** Purchase Orders, especially Initial POs, should ship 100% complete on one single dispatch/shipment.

**Ship Windows:** Zappos uses seven-day ship windows on all POs but withholds the right to extend when applicable.

**Start Ship Date:** The first date in which the PO can leave the Vendor's dock to be shipped to the FC.

**Last Ship Date:** The last date that can be selected as the Ready to Ship date for a PO in the Vendor Routing Portal.

**Ready to Ship Date:** Purchase Orders can be submitted for routing up to two weeks prior to the Start Ship Date. Routing Requests must be submitted at least one business day prior to the date the order is ready to ship. The Ready to Ship Date must fall within the Start Ship Date and Last Ship Date of all requested POs. For example, if the Vendor submits a Routing Request on Monday, the earliest the Ready to Ship Date can be is Tuesday. We do not allow same day Ready to Ship Dates on Routing Requests. Check Zapporo to ensure the PO is still within the shipping window.

**Dispatch Number:** Zappos issues a dynamic dispatch number for all shipments. This is the number that should be referenced when inquiring about any delivery. The dispatch number should also be included on the ASN (Advanced Shipping Notice - EDI 856). Refer to page 26 for the Routing Request process.

**Consolidation:** Consolidate all POs and brands to ship no more than bi-weekly and on non-consecutive days out of the same facility/address that are shipping to the same FC/address. Written authorization from the Inbound Transportation Services team must be received prior to shipping outside of these guidelines. The exception to this would be full truckload shipments (3,300 cubic feet). These can be submitted as they become available to ship without limits. The Inbound Transportation Services team may consolidate two or more Routing Requests onto a single dispatch that are destined for the same FC with Ready to Ship Dates that are in proximity to one another. The Vendor will be alerted to the consolidation via email. Additionally, the Routing Request(s) will be updated with the same dispatch number on the Routing Request Portal.

**High Volume Shipping Time Frame:** All month end Routing Requests and peak shipments (September through November) should be submitted through the Zappos Routing Request Portal at least **three business days** prior to the requested Ready to Ship Date.

**EDI Documents:** An ASN (Advanced Shipping Notice – EDI 856) and an Invoice (EDI 810) must be successfully processed for all POs. (Please see pages 6-11 for all EDI documents details.)

**Expenses:** Any non-compliance to the guidelines and policies can result in refusal of delivery. The Vendor agrees that they will bear all expenses (including but not limited to those of shipping, return shipping, and restocking) for such deliveries, unless before such shipments are made, they receive written approval from the Zappos Inbound Logistics Team. The Vendor will not be responsible for delays caused by a 3rd-party shipper if they are complying with our instructions.

**Vendor Portal:** Please refer to the Zapporo Help section on the [Vendor Resources](#) site for assistance with navigating our vendor portal, Zapporo, when creating or reviewing POs.

## SECTION 4: Imagery

### Photo PO

A Photo Purchase Order (Photo PO) is an independent PO devised to send merchandise directly from the supplier to the Zappos Photo Studios for imaging and gathering product information. The product is later shipped by Zappos to its respective FC. **Photo Purchase Orders are only created and released by the Zappos Buyer.**

Upon creation, a Photo PO will be transmitted via an EDI 850 document in the same manner as the bulk/parent PO. The default Start Ship Date of the Photo PO will be 2 weeks prior to the Start Ship Date of the original bulk PO. Other shipping intervals available are 0, 3, 7, and 10 days prior to the Start Ship Date to provide flexibility. Once approved for routing by the Zappos Inbound Transportation Services team, Photo POs will be assigned to ship UPS Next Day Air so they will be processed prior to the bulk PO arriving at the FC.

A 100% fill rate on the initial Photo PO Routing Request is required. Maximizing unit quantities from a single PO into as few shipping cartons as possible is strongly encouraged. However, please do not mix products from different POs within the same carton. **No exceptions.**

**EDI:** All EDI guidelines outlined on pages 6-11 must be followed on all Photo POs.

**Product Labeling:** All units should adhere to the same labeling guidelines found on pages 14-15

**Packaging:** All units should adhere to all of the same packaging guidelines found on pages 16-23. Units in the Photo PO must be sellable merchandise, **not sample units.**

Identifying a Photo PO from a regular PO:  
See image below.

- The PO description will include “Photo PO” and the bulk PO
- Number.
- The PO Type is set to Photo PO.
- The FC Destination is set to **ZAP1** (all photo POs will ship to this FC).

• PO Full View				• Inventory PO View		• PO History		• Item Details		Parent PO <a href="#">Link to This Page</a>	
PO Number	EXNULAO1234567	Start Ship Date	04/20/2026	Supplier	Supplier Name						
Description	Photo PO	Date	05/15/2026	Sales Site Filter	Zappos.com						
Re-Open		Export to XLS		Items highlighted in Light Blue are Direct Fulfillment stocks and cannot be released on a Wholesale pu							
• Workflow, Planning, Shipment & Terms											
Workflow											
Status	Closed	Transaction Type	Standalone Order	Owner	Creator						
Last Released	03/24/2026 02:01 PM	Primary Contact									
Buyer Category	Performance Run	Secondary Contact									
Planning											
PO Type	Photo PO		April	2026	SAP Vendor ID						
Shipment											
Shipment Type	Regular	Ready to Ship	No	Foreign Trade Zone	No						
		Allow Early Ship	No	Current FC Dest.	ZAP1						
Terms											
Payment Terms	Net 60	Std PO Discount	10%	Orig Wholesale Dsc	10%						
				Cur Wholesale Dsc	10%						

Please contact your Zappos Buyer or the Zappos Photo PO team at [zapposphotopo@amazon.com](mailto:zapposphotopo@amazon.com) with any questions. **A full Photo PO Guide and information can also be found on the [Vendor Resources](#) site.**

### Zappos Vendor Imagery Program

The Vendor Imagery Program permits the use of vendor images. Imagery can be provided directly from the supplier and processed before the bulk PO arrives at the FC, allowing inventory to go live within 24 hours of receipt. To participate in the Vendor Imagery Program, sample images must be provided for vetting and approval of required technicalities. Zappos Imagery Guidelines and Vendor Imagery Path Requirements can be found on the [Vendor Resources](#) site.

Once approved, images can be provided as soon as styles are created in Zappos systems. We request that vendor imagery be provided for all future styles. **Please provide assets at least 10 days before the PO Start Ship Date to prevent go-live delays.**

### Ways to Submit Vendor Imagery & Product Information

- Vendor initiated through Zapporo - [Zapporo Vendor Imagery Upload Tutorial](#)
- Vendor initiated sent via email to [zappos-vendorimagery@amazon.com](mailto:zappos-vendorimagery@amazon.com). Please provide a download link or asset hub link for images along with Style ID information.
- Buyer initiated upload - Vendor provides images to Zappos buyer for internal processing.
- Vendor Imagery Team initiated through outreach - Vendor Imagery Team will outreach before PO Start Ship Date to proactively collect imagery.

## SECTION 5: Product Labeling

### GS1 Certified UPC/EAN Requirements

Vendors must obtain GS1 certified UPCs/EANs (GTIN/GLN) directly from GS1. The company name listed on the GS1 certificate must match or be affiliated with the Vendor's company name. If the company name doesn't match what is listed on the GS1 certificate, Vendors will need to provide proof of the relationship. We do not accept UPC/EAN certificates from third party sellers such as nationwidebarcode.com, speedybarcode.com, barcodestalk.com, justupcbarcodes.com, etc.

Zappos verifies the authenticity of product UPCs/EANs by checking the [GS1 database](#). **Zappos will refuse and return every product that does not have a barcoded and GS1 certified UPC or EAN label with correct product data at the Vendor's expense.**

### UPC Reuse/Recycling

In accordance with GS1 standards, an item's UPC and EAN (GTIN/GLN) must not be reused. Any recycled or reused UPCs will not be accepted.

### UPC Guidelines

It is mandatory that each shippable/sellable unit has a UPC label (12 digits) or EAN label (13 digits) on the exterior of the product packaging. Only one UPC or one EAN should be printed on the label (not both). This product identification number must be barcoded, as well as printed numerically on an easily visible and scannable part of the item. All other barcodes, including QR codes, must be removed or completely covered.

The UPC or the EAN on the labels and/or hangtag must be derived from the Zappos Order that was received. No names of other retailers should appear on the labels and/or hangtags.

For all product types packaged in poly bags, a UPC/EAN hangtag or label must be attached to the product AND must be placed on the outside of the poly bag even though a hangtag or label is already provided on the product.

We cannot receive or use case pack UPCs on POs. Zappos buyers can still write POs for case packs quantities, but the PO will only list individual UPCs and not the case pack UPC. If Vendors are shipping case packs, the case pack UPCs should not be visible on the outer carton and each sellable unit must have an individual UPC label on its packaging.

If Vendors are using inner cartons/poly bags to help contain sellable units, do not place UPC labels on the outer packaging.

Products may include a MSRP pre-priced hangtag or label. Please note: Products with pre-priced labels will not be updated if the MSRP price changes.

## UPC Guidelines Continued

### Required Information on each UPC/EAN label:

- Brand Name
- Style name or number
- Color
- Size
- UPC/EAN human-readable number and barcode

### Sample UPC Label:



## UPC Style Updates

Any identifiable style changes or updates on existing styles must be communicated to the Zappos buyer prior to shipping the updated units to the FCs. Style changes can include any small color changes to the product (heel, stitching, lining, accessories, etc.), decal changes, strap/zipper changes on handbags or luggage, embellishment changes, etc. With prior notification we will be able to either update the item's description to notify our customers or we can remove the old styles, so we do not have mixed inventory.

**Major style changes will require a new style name/number and a new UPC.**

## Country-of-Origin

All products must be marked with a Country-of-Origin label. The Country-of-Origin label can either be on an affixed label, a hangtag or on a sticker. For footwear, the country of origin label must be on both shoes in the pair. Simply having the Country-of-Origin on the website or on a shoebox is not sufficient.

## Hazmat Materials

If a product is classified as Hazmat Material by the US DOT, please consult with your Zappos buyer prior to accepting the PO to ensure we can receive the product in our FC.

## SECTION 6: Packaging Guidelines

All packaging guidelines must be followed on products shipping to the FC. For non-compliance, Vendors may incur chargebacks for the actual repackaging and handling fees. Non-compliant shipments or products may be returned at the Vendor's expense.

Please Note: When product arrives at our FC, it is stowed in the next available space. All items on a PO, brands, or similar product are not stowed in the same location and will be stored with various product types. The packaging guidelines listed are required to ensure the product is protected while being stowed at our FC and shipped to our customers.

### Packaging Requirements

- All products must be packaged according to unit minimums outlined in the Product Specific Packaging and Shipping Requirements section on pages 17-19.
- POs written for less than the unit per carton minimum, should be routed and shipped 100% complete.
- All products and accompanying literature and/or accessories should be packaged inside the packaging with the unit.
- All products must be packaged and ready to ship to the customer without any additional packaging or prep required by Zappos.
- Do not bundle individual UPCs into case packs. All UPCs must be individually packaged per UPC unit.
- All hangers must have metal hooks and the arms must be plastic or wood. Any units sent with plastic hook hangers will not be hung.

### Poly Bag Requirements

- **Poly bags can vary in width and length as long as they do not protrude more than 3 inches past the dimensions of the product.**
- Poly bags must be completely sealed on all products. Flutter holes are not allowed.
- Poly bags must be clear and transparent. Colored poly bags are not allowed.
- All poly bags must adhere to the suffocation warning guidelines listed below.

### Suffocation Warning

Zappos requires Vendors to comply with all applicable state and local laws, rules, regulations, ordinances, and directives with respect to product packaging materials. Vendors should direct any related questions to their legal counsel. Generally, suffocation warnings should be present on all plastic bags (1 mil or less thickness) that have a 5" or greater opening and are used to protect product. Required warning language and presentation requirements may vary on the state and local levels. At a minimum, Zappos recommends that Vendors include a message on plastic bags consistent with the following:

*WARNING: To avoid danger of suffocation, keep this plastic bag away from babies and children. Do not use this bag in cribs, beds, carriages or play pens. This bag is not a toy.*

The print size of the above warning should conform to the following table:

Total Length plus Width of Bag	Minimum Print Size
60 inches or more	24 point
40 to 59 inches	18 point
30 to 39 inches	14 point
less than 29 inches	10 point

## Product Specific Packaging and Shipping Requirements

Product Type	Products	Packaging Type	Packaging and Shipping Requirements
<p><b>Adult &amp; Children’s APPAREL/CLOTHING:</b></p> <p>Product should be folded neatly within its packaging. Apparel should not be packaged on hangers unless the product type specifically requires a hanger.</p>	Shirts, Tops, Pants, Bottoms, Shorts, Jeans, Skirts, Casual Dresses	Poly bags	Folded and bagged. Do not use hangers. A minimum of 5 units per shipping carton. Any items over \$500.00 MSRP must be boxed or on a hanger and in a sealed poly bag or garment bag.
	Swimwear, Sleepwear, Underwear, Intimates	Poly bags	Sets must be packaged together. Do not use hangers. A minimum of 5 units per shipping carton. Swimwear must have the required protective, hygienic and adhesive liners.
	Formal Wear, Wedding, Ball Gowns, Suits	Boxes or garment bags and on hangers	Must be boxed and lie flat or packed in garment bags on hangers. A minimum of 5 units per shipping carton.
	Coats, Outerwear, Blazers, Jackets, Leather Apparel	Poly bagged or on hangers	Folded at least once or on a hanger. Must be in a sealed poly bag or garment bag. A minimum of 5 units per shipping carton.
	Ties	Poly bags or boxes	Must be in a sealed poly bag or a sealed cardboard box. Boxes with lids must be sealed with tape or cardboard sleeve. It is preferred that ties packaged in poly bags are rolled. A minimum of 5 units per shipping carton.
	Plush Robes	Poly bags	Folded and poly bagged. Do not use hangers. A minimum of 5 units per shipping carton. Any items over \$500.00 MSRP must be boxed or on a hanger and in a sealed poly bag or garment bag.
<p><b>SOFT GOODS:</b></p>	Socks	Poly bags or boxes	Socks are to be packaged in the unit amount as they are to be sold (e.g., 2 pairs = 1 unit, 4 pairs = 1 unit, etc.). If socks are to be sold in multi-paired packs, they must have a different UPC on the poly bag than the single paired units. Any old UPC labels that were once placed on a single pair unit but are now bundled to be sold as a multi-paired pack must be removed or covered from the packaging. Do not bundle individual units in case packs.
	Hosiery, Gloves, Scarves	Poly bags, chipboard boxes, or boxes	Sets must be packaged in the unit amount they are to be sold. Small hook hangers need to be removed or completely covered by an outer poly bag. The outer packaging must have a UPC/EAN label.
	Hats	Poly bags or boxes	Fragile, fashion, or straw hats must be packaged individually in boxes to prevent damage.
	Belts	Poly bags, chipboard boxes, or boxes	Product <b>AND</b> outer packaging must have UPCs/EANs. Products must be individually packaged per the UPC unit. All belts packaged in poly bags must be rolled.

Product Type	Products	Packaging Type	Packaging and Shipping Requirements
<b>BAGS &amp; LUGGAGE:</b> All units should be packaged separately unless they are sold as a set.	Handbags, Diaper Bags, Back Packs, Bags	Poly bags	Poly bag should be sealed.
	Luggage	Boxes	Each individual sellable unit should be packaged separately. Do not ship luggage nested unless they will be sold as a set. See Shipping Carton Dimensions for details. (Pages 25).
<b>ELECTRONICS:</b>	Headphones, Portable Electronics, GPS	Boxes	Must be in a box to prevent damage.
	Phone Case / Tech Accessories	Boxes or Poly bags	Must be in a box or poly bag to prevent damage.
<b>FOOTWEAR:</b> Maximize product quantity packed per shipping carton. Do not wrap individual footwear boxes in additional materials such as rubber bands, shrink wrap, etc.	Shoes	Boxes	A minimum of 10 pairs per shipping carton.
	Boots	Boxes	A minimum of 6 pairs per shipping carton.
	Sandals, Flip-flops, Slippers	Boxes or Poly bags	A minimum of 10 pairs per shipping carton. All poly bagged units must include a UPC label on the outside of the poly bag and on the item itself.
<b>HOUSEWARES &amp; HOME GOODS:</b> Only heavy product should be palletized.	Kitchenware (Tools, Utensils, etc.)	Boxes	Sets must be packaged together. See Sharp or Damage-Prone Items section on page 23.
	Glassware	Boxes	See Sharp or Damage-Prone Items section on page 23.
	Bedding, Towels	Boxes or Poly bags	Sets must be packaged together.
	Small Décor	Boxes	Sets must be packaged together.
	Lamps/Lighting Fixtures, Holiday Ornaments	Boxes	Packaging must be durable and secure to prevent damage. See Sharp or Damage-Prone Items section on page 23.
	Rugs, Framed Art	Boxes or Poly bags	Rugs must be rolled and bound in poly bags.
	Appliances	Boxes	See Sharp or Damage-Prone Items section on page 23.
	Candles	Boxes	Product must be in sealed box.

Product Type	Products	Packaging Type	Packaging and Shipping Requirements
<b>OUTDOOR/INDOOR SPORTING GOODS &amp; GEAR:</b>	Sports Gear, Sports Accessories	Boxes or Poly bags	All golf clubs must be in individual protective boxes that encompass the shaft and head of the club. Skateboards must be individually boxed. Yoga mats must be individually packed.
	Balls, Basketballs, Soccer Balls, Baseballs, etc.	Boxes	All balls must be inflated and individually packaged.
	Pet Accessories	Boxes or Poly bags	Product must be in sealed poly bags or box.
	Camping Furniture	Boxes or Poly bags	Palletize heavy products. Shipping carton should not exceed 50 pounds.
	Bottles	Boxes or Poly bags	Water Bottles must be in sealed poly bags or individually boxed.
<b>TOYS:</b> Under the U.S. laws and regulations including, without limitation the Consumer Product Safety Improvement Act, a Certification of Conformity must be provided for each product prior to shipment.	Children’s Toys	Boxes	Product must conform to the CPSIA. Vendors with products requiring a choking/small parts hazard warning must notify their buyer during the catalog setup process.
	Strollers, Stroller Accessories	Boxes	Product must conform to the CPSIA.
<b>ACCESSORIES:</b> Product must be shipped within their case and assembled prior to shipping. Minimum of 10 units per shipping Carton.	Sunglasses	Boxes	The product’s outer packaging must have UPCs/EANs and be individually packaged. All cases should be packaged inside the box with the individual unit.
	Jewelry	Boxes or Poly bags	The product’s outer packaging must have UPCs/EANs and individually packaged. Please see page 21 for additional guidelines.
	Watches	Boxes	The product’s outer packaging must have UPCs/EANs and individually packaged. Please see page 21 for additional guidelines.

## Additional Product Packaging Recommendations

The recommendations listed below help ensure our customers receive products in good condition and provide for the best customer experience.

### Footwear

- If footwear units are packaged in tissue paper, the units should be completely wrapped with no exposed material coming into contact with the shoe box.
- All closed-toe shoes should have tissue paper inside (excluding women's pumps).
- Footwear should be presented symmetrically; cardboard inserts must be present in both shoes or not at all.
- Laces should match on each pair of shoes. (If one shoe is laced up, the other shoe should be laced as well.)
- Shoe boxes should not have holes, rips, water damage, or crushed corners (box thumbholes are acceptable).



### Apparel

- Place individual units of apparel and products made of fabric or textiles, along with any cardboard backings, in transparent, sealed bags or shrink wrap (minimum of 1.5 mil) clearly marked with a suffocation warning label.
- All buttons and clasps must be closed.
- Fold items to the smallest dimensions to fit in the package.
- Fold all clothing neatly to its minimal dimensions and place it in an exact-fit bag (Poly bags should not protrude more than 3 inches past the dimensions of the product) or box. Make sure boxes aren't creased or broken.
- Use boxes and tissue paper for materials such as leather that could be damaged by bags or shrink wrap.



## Watch and Jewelry Guidelines

All jewelry and watches with a minimum retail price of \$500 will go through a Quality Assurance Inspection (QAI) in our FCs. Zappos will return any products that are received damaged at the Vendor's expense. **Please note, any products over \$500 should be on separate POs from products under \$500 for ease of identification and timely QAI.**

### Watches

Watches must be shipped within their case and assembled prior to shipping. The product/UPC labeling should be on the outside of the box and not on the actual watch. Watches should not move or shake within the container and should pass a vigorous shake test without having items break or be damaged.

Packaging Standards are defined below:

- Plastic sleeve, bubble wrapping or plastic film around the watch to prevent the product from being damaged.
- Foam or soft insert that lays on top of the watch within the case to secure item within the case.
- Outer case that holds the watch and any accessories that accompany the product.
- Sealed poly bag or outer box that protects the watch and/or case.
- All Smart Watches must have a factory tamper seal.



**Foam Insert**



**Plastic Film**



**Bubble Wrap**

### Jewelry

Jewelry must be shipped individually per the unit/UPC quantity. Do not bundle separate jewelry units together. All jewelry accessories (cleaning cloths, storage bags, cards, etc.) should be packaged inside the poly bag or box with the individual unit. Do not ship jewelry accessories separate from the individual unit. Zappos will not perform additional packaging prep prior to shipping to the customer.

Packaging standards are defined below:

- Product's outer packaging should have UPCs/EANs.
- Jewelry boxes with lids should be sealed with tape.
- Products in poly bags should be sealed or taped closed. Do not seal with a staple closure.



## Liquids

Liquid products (or product containing liquids) will only be accepted if they possess the following characteristics and conform to the associated packaging requirements and restrictions below.

Note: Any products which do not meet the characteristics and associated packaging requirements indicated in the below table cannot be accepted into our FC and will be returned at the Vendor's expense.

### **Additional requirements for all liquids:**

Product Characteristics			Packaging Requirements			
Container Type	Sellable Unit	Sellable Unit Dimensions	Sellable Unit Package	Sellable Weight / Volume Restriction	Inner Pack Volume	Seal
Glass	Single unit	Less than 8" x 14" x 18"	None	Vol of 4oz or less	N/A	Double sealed screw cap
Plastic	Single unit	Less than 8" x 14" x 18"	None	Vol of 50oz or less	N/A	Double sealed screw cap
Plastic	Multi-unit, physically bundled	Less than 8" x 14" x 18"	Corrugate Box	Vol of 50oz or less	68 ounces or less	Double sealed screw cap
Plastic	Multi-unit, physically bundled	Greater than 8" x 14" x 18"	Corrugate Box	N/A	No restrictions	Double sealed screw cap

Corrugated containers on multi-unit bundled products must meet the following criteria:

- Must have a box certificate seal.
- Product is in a 6-sided box.
- Carton does not give way when pressure is applied to any of the sides.
- No side of product carton has an opening that makes some of the contents visible from the outside.
- Product contents are securely held in place inside of the carton.
- Carton is sealed with tape or glue.
- Carton has clear markings indicating which box side is the top.
- Carton must not contain hazardous materials as defined by US DOT regulation.

## Drop Test

Each sellable unit must be able to pass a drop test consisting of the following: Item should be dropped four consecutive times from a height of 24 inches onto a concrete surface, once on the top, once on the bottom, once on the bottom corner, once on the longest bottom edge. A single test article must survive a single test (four drops). Success is a leak-free container. Damage to the container that does not cause leaks is acceptable.

## **Sharp or Damage-Prone Items**

Zappos reserves the right to specify product needing additional protective packaging in order to preserve the integrity of the product throughout the fulfillment process. Any product with the following attributes, delivered to the FC in inadequate or noncompliant packaging will be refused or repackaged by Zappos at the Vendor's expense, and may be subject to non-compliance fees.

### **Sharp Items**

Sharp products (i.e., any product that has a sharp or pointed edge such that when exposed, the edge would present a safety hazard to associates, carriers, or customers receiving or unpacking the product) must be packaged so that in the normal course of order fulfillment (i.e., receipt, stocking, shipment preparation and transit to the customer), the sharp or pointed edge will not become exposed. Any sharp products that do pose a safety risk may be rejected at the dock and returned at Vendor's expense.

- To provide the safest packaging, sharp items should be blister-packed. The blister-pack must cover the sharp edge and be securely fastened to the item so that the item does not slide around within the blister pack.
- Place or wrap the unit in protective bubble wrap or a protective over box, so that the packaging completely covers any exposed edges. A product that is over boxed is placed in an additional box at the time of shipping. Make sure the barcode can be scanned without opening or unwrapping the unit.
- Sharp products secured to a footprint and wrapped in plastic may also be allowed provided that the item is secured to the footprint (i.e., does not slide around), the plastic is rigid enough to withstand handling and exterior contact does not cause the sharp product to perforate the plastic.

### **Glass, Ceramic, Breakable and Fragile**

This section describes any product of extremely delicate material or construction and is in need of careful handling to avoid breakage or damage. These items may present a safety hazard to associates, carriers, or customers receiving or unpacking the product. Breakable products must be packaged so that in the normal course of the fulfillment process they cannot be broken or exposed.

- Items must come in a six sided solid box so the item is not exposed in any way.
- All items must be individually wrapped to prevent damage from other items within the container (e.g., set of four wine glasses).
- The packaged items must pass a drop test consisting of the following: Packaged items should be dropped five consecutive times from a height of 36 inches onto a concrete surface, once on the top, once on the bottom, once on the longest side, once on the bottom corner, once on the longest bottom edge.
- Items should not move or shake within container and should pass a vigorous shake test without having items break.
- Palletize only glassware or breakable products. Wrap item(s) in protective bubble wrap or over box to prevent damage.

**If you cannot comply to any of the packaging guidelines listed on pages 16-23 please email [zappos-vendorsupport@amazon.com](mailto:zappos-vendorsupport@amazon.com).**

## SECTION 7: Proposition 65

If a Vendor provides products that require a warning under California Health & Safety Code Section 25249.6 (a “Proposition 65 Warning”), then they must comply with the following for such products:

For each product that requires a Proposition 65 warning, Vendor (a) will provide Zappos with such warning as directed by Zappos and in accordance with the step-by-step instructions located on our [Vendor Resources](#) site (b) agrees that Zappos’ display of the Proposition 65 Warning on a product detail page is confirmation of our receipt of that warning, and (c) will only revise or remove a Proposition 65 Warning for a product when the prior warning is no longer legally required.

## SECTION 8: PFAS (Per- and Polyfluoroalkyl Substances)

Zappos does not accept any children’s/juvenile products that contain regulated PFAS, as defined in California Assembly Bill No. 652. Additionally, Zappos does not accept any textile articles that contain regulated PFAS except for outdoor apparel for severe wet conditions as defined in California Assembly Bill 1817. If a Vendor sells any children’s/juvenile products or textile articles to Zappos that contain regulated PFAS, Vendor must notify Zappos immediately and will accept the products as returns at the Vendor’s expense.

## SECTION 9: Shipping Carton Information

**Master Shipping Carton: All individual products must be packed in a master shipping carton.** Do not use staples to secure cartons. Remove any plastic or metal banding prior to shipping. Cartons need to be sealed tight to prevent damages.

### Master Shipping Carton Packing:

- Maximize unit quantities into master shipping carton.
- Zappos encourages packing multiple styles, sizes and/or colors in one shipping carton as long as all items in the carton are on the same PO.
- Do not use loose fill dunnage of any kind such as: Styrofoam peanuts, shredded paper, etc.
- Do not mix multiple POs in a carton.
- Do not mix multiple product types in a carton. POs should not have multiple product types. For example, footwear and clothing are sent to separate FCs so they will be on separate POs.
- Shipping cartons and shipping labels should not include any other company’s name, address, information, etc. Any additional information that is unrelated to the Zappos PO should be completely removed or covered.
- Contact [zappos-vendorsupport@amazon.com](mailto:zappos-vendorsupport@amazon.com) if a unit is over the size and weight dimensions listed above or if you are unsure of carton packing.

***The Zappos Inbound Transportation Services team reserves the right to require the Vendor to repack items into fewer master shipping cartons when unit per carton minimums are not met and/or it is clear that unit quantities were not maximized into master shipping cartons. (i.e. 6 units of footwear routed and packed in 6 master shipping cartons).***

### Master Shipping Carton Labels:

Every master shipping carton in the shipment **must have** an EDI GS1-128 Shipping Label on the outside of the carton. An **EDI GS1-128 Shipping Label** must include a human-readable and scannable Zappos Purchase Order Number barcode and an SSCC-18 barcode. When the EDI GS1-128 shipping label is submitted, an EDI 856 – Advance Ship Notice (ASN) including SSCC-18 information must be submitted prior to shipment. See pages 9-11 for the EDI GS1-128 Shipping Label specifications.

**Zappos will refuse and return at the Vendor’s expense every shipping carton that does not have a compliant EDI GS1-128 Shipping Label on the outside of the carton.**

## Shipping Carton Label Placement

The shipping carton label should be placed on the exterior of each carton in an unobscured and easily visible location, preferably on the side of the carton. Do not place carton labels over a seam of the carton. To preserve the readability of carton labels, place them on cartons at least 1" away from corners, edges or tape that may cover or distort the label. Avoid placing labels near corners as this may be crushed or collapsed while in transit. Typically, labels are only placed on the top of a carton when the sides are too short (less than 7" H) to fit the label. See diagrams below for recommended and NOT recommended ways of placing top and side shipping labels.

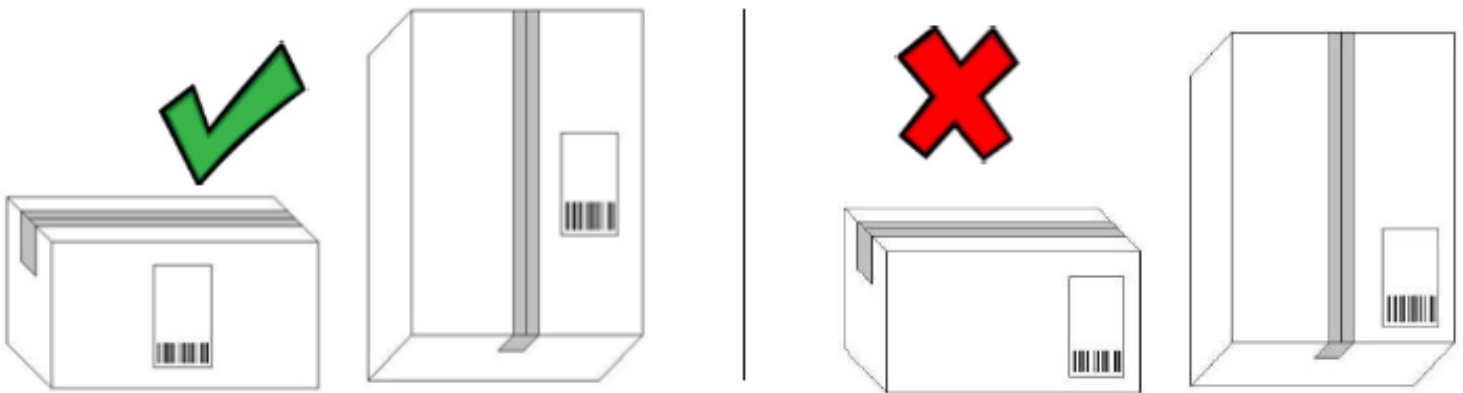

## Shipping Carton Dimensions

The following applies to ALL shipping cartons:

- The maximum shipping carton weight is 50 pounds.
- The minimum shipping carton dimensions are (8" L x 6" W x 6" H).
- **The maximum shipping carton dimensions are:**
  - **Footwear: 32" L x 24" W x 27" H**
  - **All Non-Footwear products: Carton must not exceed 25" on any side (unless individual product is >25").**
- Carton openings should be on the top or bottom and not on the sides of each carton.
- Carton dimensions are based on FC conveyance systems. Cartons that exceed our dimensions cannot follow our normal receiving process and are sidelined to be received manually which causes delays.

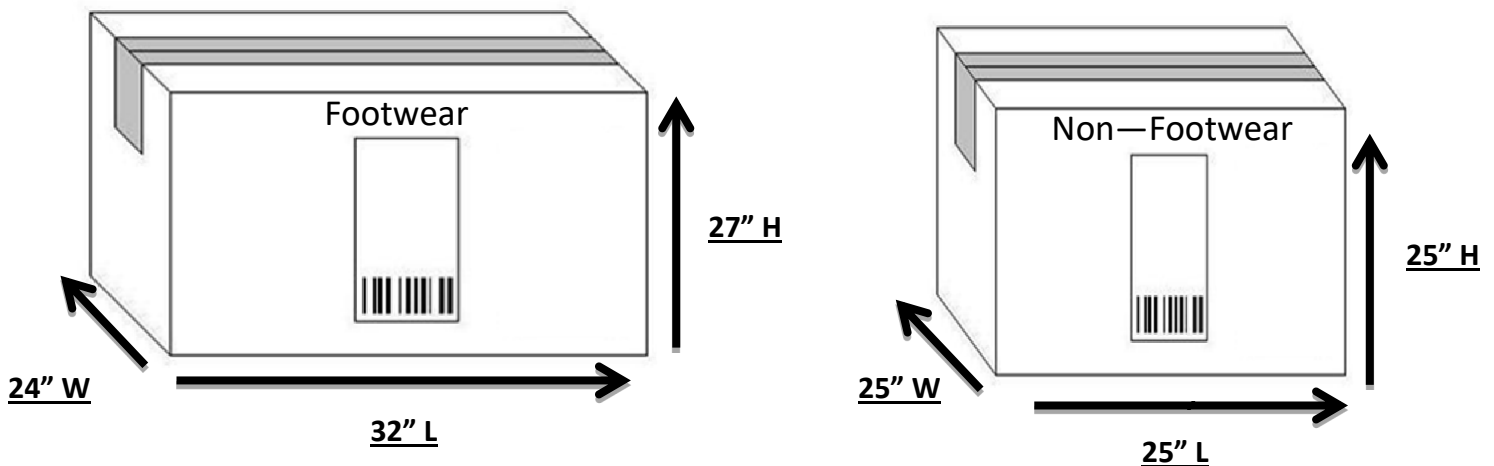

## SECTION 10: Zappos Routing Request Portal

It is required that ALL shipments are approved by the Inbound Transportation Services team prior to the Vendor or their agents tendering freight to any carrier. This includes UPS and other small parcel carriers as well as Vendor paid shipments.

**Failure to submit a Routing Request and comply with the carrier assignment may result in chargebacks.**

Please review the instructions on how to use the Zappos Routing Request Portal on page 39 and use the below link to access the portal. Zappos only accepts and processes Routing Requests submitted via the Routing Request Portal. Requests must be submitted at least one business day prior to the Ready to Ship Date.

[Routing Request Portal](#)

A shipment is not approved to ship until a dispatch number has been assigned to the Routing Request. This number is required on the EDI-856 ASN.

**Ship to Address:** All Purchase Orders (domestic & international) must ship to the address that appears on the PO (or to any other address Zappos authorizes in writing or through the Zappos Vendor Portal).

**Below is the information to be included on the Routing Request for domestic shipments:**

- Valid Zappos Purchase Order Number (1-22 alphanumeric characters).
- Accurate total number of cartons per PO.
- Accurate total number of units of product per PO.
- Total actual weight in pounds (lbs.) per PO.
- Cubic feet per PO: Formula for cubic feet: (L" x W" x H") / 1728 = cube per carton then take the cube per carton x number of cartons = total cubic feet.
- Accurate Pallet Count (if applicable).
- Accurate Ready to Ship Date.
- The address and shipping hours of the pick-up location (e.g. supplier warehouse).
- Origin contact person with e-mail address and phone number.

Zappos does not require packing lists for our domestic inbound shipments. However, if it is part of a Vendor's standard routine to attach or include a packing slip with the PO, please feel free to do so.

Deviation from the number of cartons/units approved to ship and the number of cartons/units physically shipped must be communicated by Vendor/shipper via email to [zappos-traffic@amazon.com](mailto:zappos-traffic@amazon.com) within 24 hours after shipment has departed their facility. Failure to notify [zappos-traffic@amazon.com](mailto:zappos-traffic@amazon.com) of any discrepancies may result in chargeback and/or return at Vendor's expense.

## SECTION 11: Zappos Paid Freight

Upon approval of the Routing Request submitted via the Zappos Routing Request Portal, Vendors will receive instructions via e-mail from our Inbound Transportation Services team. These instructions will include whether the shipment is approved to ship via small package carrier, Less-Than-Truckload (LTL) or Truckload (TL). Loading requirements are listed on pages 32-33. If you have specific palletizing questions, please contact [zappos-traffic@amazon.com](mailto:zappos-traffic@amazon.com).

### Vendors who have been approved to ship via UPS:

On the Vendor provided Ready to Ship Date of the approved dispatch, an email will be sent containing pre-paid UPS Ground carton labels. Vendors have the option to print and apply 8 ½" X 11" paper labels or 4" X 6" thermal labels. Once this email is received, please proceed with the following steps.

#### Instructions for 8 ½" X 11" Paper:

1. Open the attached "UPS Labels" PDF file and print the label(s) onto standard 8 ½" X 11" paper(s).
2. Fold each printed label at the dotted line. Place each label in a UPS Shipping Pouch. If a Vendor does not have a pouch, affix each folded label using clear plastic shipping tape over the entire label.
3. Securely apply one label per carton while being sure to leave any barcodes clearly visible for scanning. Ensure the GS1-128 carton label and the prepaid UPS shipping label are both visible on each shipping carton.
  - a. The PO# will be clearly marked on each UPS Label. If shipping more than one PO please ensure that the labels for each PO are applied to the corresponding PO's cartons.
4. Have the carton(s) ready for the Daily UPS Collection driver as usual or take the package(s) to any UPS location such as: The UPS Store®, UPS Customer Center, UPS Alliances (Office Depot® or Staples®) or an authorized shipping outlet near you.

#### Instructions for 4" X 6" Thermal Labels:

1. Open the attached "UPS 4x6 Labels" PDF file and print the label(s) onto standard 4" X 6" thermal label(s).
2. Fold each printed label at the dotted line. Place each label in a UPS Shipping Pouch. If a Vendor does not have a pouch, affix each folded label using clear plastic shipping tape over the entire label.
3. Securely apply one label per carton while being sure to leave any barcodes clearly visible for scanning. Ensure the GS1-128 label and the prepaid UPS shipping label are both visible on each shipping carton.
  - a. The PO# will be clearly marked on each UPS Label. If shipping more than one PO please ensure that the labels for each PO are applied to the corresponding PO's cartons.
4. Have the carton(s) ready for the Daily UPS Collection driver as usual or take the package(s) to any UPS location such as: The UPS Store®, UPS Customer Center, UPS Alliances (Office Depot® or Staples®) or an authorized shipping outlet near you.

All products and cartons must comply with all federal, state and local carrier HAZMAT laws, regulations and guidelines.

**Please note:** GS1-128 Shipping Labels are still required when shipping cartons via small package carrier.

### Vendors approved to ship via LTL or Truckload (TL/3PL):

If instructed to use our 3PL carrier, please follow the guidelines below:

- **Shipment Reference Number (DISPATCH NUMBER):** Upon approval, Vendors will receive a shipment reference number to be listed on all corresponding documents (e.g., "Dispatch # 111111").
- **3PL Service Expectation:** Our 3PL will exhaust all efforts to assign a carrier to pick up a Vendor's shipment within two business days of the Ready to Ship Date. Our 3PL will send you an email with your carrier assignment, load details, BOL instructions and pick up date no later than one day prior to the pickup date.  
(cont'd on page 28)

- **Notification of Changes:** The Zappos Inbound Transportation Services team must be notified by e-mail at [zappos-traffic@amazon.com](mailto:zappos-traffic@amazon.com) of all changes and/or discrepancies on approved shipments immediately upon discovery. Failure to alert [zappos-traffic@amazon.com](mailto:zappos-traffic@amazon.com) may result in the inability to route and ship back ordered items.
- **Pick-up & Delivery:** As per the aforementioned 3PL Service Level Agreement, all efforts will be made to schedule domestic pick ups within two business days of confirmed Ready to Ship Date. Higher than average shipping volumes and FC receiving capacity may extend the window between the confirmed Ready to Ship Date and the actual scheduled pick-up date beyond two business days.
  - 3PL will schedule the delivery.
  - Unauthorized shipments or deliveries will be refused at the Vendor's expense.
- **No C.O.D:** Do not ship Cash on Delivery (C.O.D.). Shipments shipped on C.O.D. will be refused.
- **Security Seal:** Shippers must provide and apply a single use security seal for TL shipments. Seal number must be notated on the Bill of Lading. Shortage claims against a TL shipment without a notated security seal number will not be honored.

### Standard Bill Of Lading (BOL)

Standard Bill Of Lading (BOL) is a detailed list of a shipment of goods in the form of a physical document given by the carrier to the person consigning the goods. It is the shipper's responsibility to have a complete and accurate BOL prepared for the driver at the time of pickup. Failure to provide accurate information on the BOL could result in delay of pickup or delivery of your goods. No more than one BOL should be used per shipment pick up. All orders shipping from one location to a single fulfillment center must ship as one shipment, with one tracking PRO Number (when applicable) from the carrier. BOL must include the Zappos PO number and dispatch Number. All quantities, description of articles and the NMFC Number must be accurately listed on the BOL. The 3rd party billing information will be provided by our 3PL, and must be clearly listed on the BOL under 3rd party billing. All BOLs should be signed for "Shipper Load and Count". A BOL can be retrieved on the Routing Request Portal once the shipment is in a "Carrier Assigned" status.

- BOL# should be unique for every shipment. It should not be repeated for a Vendor.
- BOL# should not be a single character.
- BOL# should not be a date/time.
- BOL# can be the dispatch number.

Sample BOL pictured to the right.

VICS Standard BOL: WWW.VICS.ORG For Complete VICS BOL Guide/line Information

Date: _____										<b>BILL OF LADING</b>										Page _____	
<b>SHIP FROM</b>										Bill of Lading Number: _____											
Name: _____ Address: _____ City/State/Zip: _____ SID#: _____										BAR CODE SPACE											
<b>SHIP TO</b>										CARRIER NAME: _____											
Name: _____ Location #: _____ Address: _____ City/State/Zip: _____ CID#: _____										Trailer number: _____ Seal number(s): _____											
<b>THIRD PARTY FREIGHT CHARGES BILL TO:</b>										SCAC: _____											
Name: _____ Address: _____ City/State/Zip: _____										Pro number: _____											
SPECIAL INSTRUCTIONS: _____										BAR CODE SPACE											
Freight Charge Terms: (freight charges are prepaid unless marked otherwise)										Prepaid _____ Collect _____ 3 <sup>rd</sup> Party _____											
										<input type="checkbox"/> Master Bill of Lading; with attached underlying Bills of Lading											
										<input type="checkbox"/> (check box)											
<b>CUSTOMER ORDER INFORMATION</b>										<b>CUSTOMER ORDER INFORMATION</b>											
CUSTOMER ORDER NUMBER				# PKGS		WEIGHT		PALLET SLIP (YES OR NO)		ADDITIONAL SHIPPER INFO											
								Y N													
								Y N													
								Y N													
								Y N													
<b>GRAND TOTAL</b>																					
<b>CARRIER INFORMATION</b>										<b>CARRIER INFORMATION</b>											
HANDLING UNIT		PACKAGE		WEIGHT		H.M. (X)		COMMODITY DESCRIPTION						LTL ONLY							
QTY TYPE		QTY TYPE						Commodity requiring special or additional care or attention in handling or stowing must be so marked and packaged as to ensure safe transportation with ordinary care. See Section 21g of NMFC/Inc 380						NMFC # CLASS							
<b>GRAND TOTAL</b>										<b>GRAND TOTAL</b>											
Where the rate is dependent on value, shippers are required to state specifically in writing the agreed or declared value of the property as follows: *The agreed or declared value of the property is specifically stated by the shipper to be not exceeding _____ per _____										COD Amount: \$ _____											
										Fee Terms: Collect: <input type="checkbox"/> Prepaid: <input type="checkbox"/> Customer check acceptable: <input type="checkbox"/>											
<b>NOTE: Liability Limitation for loss or damage in this shipment may be applicable. See 49 U.S.C. § 14706(c)(1)(A) and (B).</b>										The carrier shall not make delivery of this shipment without payment of freight and all other lawful charges.											
RECEIVED, subject to individually determined rates or contracts that have been agreed upon in writing between the carrier and shipper, if applicable, otherwise to the rates, classifications and rules that have been established by the carrier and are available to the shipper, on request, and to all applicable state and federal regulations.										Signature _____ Shipper											
<b>SHIPPER SIGNATURE / DATE</b>										<b>Trailer Loaded:</b>				<b>Freight Counted:</b>				<b>CARRIER SIGNATURE / PICKUP DATE</b>			
This is to certify that the above named materials are properly classified, described, packaged, marked and labeled, and are in proper condition for transportation according to the applicable regulations of the U.S. DOT.										<input type="checkbox"/> By Shipper <input type="checkbox"/> By Driver				<input type="checkbox"/> By Shipper <input type="checkbox"/> By Driver/pallets said to contain <input type="checkbox"/> By Driver/Placards				Carrier acknowledges receipt of packages and required placards. Carrier certifies emergency response information was made available and/or carrier has the U.S. DOT emergency response guidebook or equivalent documentation in the vehicle.  Properly described above or marked in good order, except as noted.			

## **Master Bill of Lading**

A master BOL must be used when multiple Dispatch #s are combined to ship together on the same truck, same day from and to the same location. Only a single PRO# should be applied to the first page of the master BOL. There should be no additional PRO#s on any underlying BOL pages. Any underlying BOLs are acceptable and can be signed by the driver making the pickup.

## **SECTION 12: Vendor Paid Freight (Prepaid/Direct Delivery)**

“Direct Delivery” means that you, the Vendor, are choosing to ship at your own expense via the carrier of your choice. Zappos will not be responsible for any shipping, storage or accessorials charges related to the transport of these goods.

***Direct Deliveries require an approval from the Inbound Transportation Services team prior to shipping. To obtain approval, a Routing Request must be submitted via the Routing Request Portal:***

1. On the Vendor Routing Request Portal, please ensure that you select the “Direct Delivered” option.
2. Once your Direct Delivery Routing Request has been approved, an email with an assigned “Dispatch Number” will be sent to the email addresses provided in the Routing Request. It is then the responsibility of the Vendor to provide specific shipment details based upon their chosen method of transport.



The screenshot shows a web form titled "Routing Request View". It contains several fields: "Routing Status" (Initiated), "Ship To" (C/O AMAZON.COM KYDC LLC, 376 AMAZON.COM BLVD, Shepherdsville, KY 40165 USA), "Created Date", "Created By", and "Creator ID". A "Direct Delivered" checkbox is present and is highlighted with a yellow arrow. Below the form are three buttons: "Save Only", "Submit", and "Upload".

**All cartons must meet both minimum and maximum shipping carton dimensions as stated on page 25 and be packed in accordance with the “Packaging and Shipping Requirements” guidelines on pages 17-19.**

### **Shipping via Small Package Carrier**

Small Package Carrier shipments are limited to one shipment per day and are limited to 20 shipping cartons or less per shipment. Shipments exceeding 20 cartons must ship via an LTL or TL Carrier.

The Small Package Carrier of your choosing is required to secure a delivery appointment. Please see below for additional instructions on securing a delivery appointment.

Once shipped, please reply to your approval email with the name of the Small Package Carrier as well as the Tracking Number(s).

- Small Package shipments addressed to ZAP1 - 101 S. Baldwin Street, Madison, WI 53703
  - Please email [zappos-XUXDock@amazon.com](mailto:zappos-XUXDock@amazon.com) to schedule your delivery appointment rather than using the Carrier Central link.
- Small Package shipments to all other FC locations
  - Please have your carrier secure a delivery appointment using the Amazon Carrier Central System

## Shipping via LTL Carrier

A delivery appointment is required for LTL Shipments. A minimum of 100 cartons is required to obtain a “Live Unload” delivery appointment. Any shipment less than 100 cartons will need to be scheduled as a “Drop Trailer” appointment or deliver via small package carrier.

Once shipped, please reply to the email sent by our Inbound Transportation Services team and provide us with the name of the LTL Carrier as well as the PRO Number(s).

- LTL shipments addressed to ZAP1 - 101 S. Baldwin Street, Madison, WI 53703
  - Please email [zappos-XUXDock@amazon.com](mailto:zappos-XUXDock@amazon.com) to schedule your delivery appointment rather than using the Carrier Central link.
- LTL shipments addressed to all other FC locations
  - Please reply to the email sent by our Inbound Transportation Services team and provide us with your chosen LTL Carrier, desired delivery date and time as well as whether your LTL Carrier requires a “Live Unload “or “Drop Trailer” appointment. The Inbound Transportation Services team will request a delivery appointment via the Amazon Carrier Central System. Once the delivery appointment has been scheduled/approved by the designated Amazon FC Inbound team, Zappos Inbound Transportation Services team will send you all the pertinent information via email so you can forward the information to your carrier.

## Shipping via TL Carrier

A delivery appointment is required for TL Shipments.

- **TL shipments addressed to ZAP1 - 101 S. Baldwin Street, Madison, WI 53703**
  - Please email [zappos-XUXDock@amazon.com](mailto:zappos-XUXDock@amazon.com) to schedule your delivery rather than using the Carrier Central link. All delivery appointments to this location will be scheduled as a Live Unload.
- **TL shipments to all other FC locations**
  - A minimum of 100 cartons is required to obtain a “Live Unload” delivery appointment. Any shipment less than 100 cartons will need to be scheduled as a “Drop Trailer” appointment or deliver via small package carrier.
  - Please reply to the email sent by our Inbound Transportation Services team and provide us with your chosen TL Carrier, desired delivery date and time as well as whether your TL Carrier requires a “Live Unload “or “Drop Trailer” appointment. The Inbound Transportation Services team will request a delivery appointment via the Amazon Carrier Central System. Once the delivery appointment has been scheduled/approved by the designated Amazon FC Inbound team, Zappos Inbound Transportation Services team will send you all the pertinent information via email so you can forward the information to your carrier.

## SECTION 13: Pallet Requirements

Shipments should default as palletized, unless the shipment is destined to SDF4 (full TLs) in which floor loaded is required. Small parcel carriers such as UPS may be floor loaded and/or palletized.

### Acceptable Pallet Types

- Use GMA grade B or higher, 40" x 48" / 1m x 1.25m 4-way access, wood pallets.
- CHEP or PECO pallets meeting GMA grade B industry standards are acceptable. However, CHEP or PECO pallet returns or exchanges are not acceptable.
- Pallet slats must be less than 5" apart to reduce opportunity for compression damage.
- Do not use pallets that are broken or pallets with missing slats.
- Do not ship items on pallets made of weak materials, such as cardboard or particle board.
- Do not ship items in gaylords (pallet-sized cartons).
- Pallets that break these compliance measures are subject to refusal at the dock due to safety concerns.

### Pallet Building Guidelines

- Regardless of pallet height, pallets must not exceed 1600.0 lbs/726 kg in gross weight.
- Securely stretch-wrap cartons to pallets or secure larger items to pallets using non-metallic bands.
- Ensure that stretch-wrap completely affixes product to the pallet, to prevent shifting during transit and creates a stable platform for pallet stacking in transit.
- The use of clear stretch-wrap (vs. black) is preferred.
- Use corner boards to help protect and maintain the stability of cartons in transit. Inventory must be loaded on the pallet in a stable way so when the stretch wrap is removed inventory will not easily fall over but remain stable on the pallet.

### Stacking

- Build pallets with the carton labels facing outwards to allow each barcode on the carton to be scanned without breaking down the pallet.
- Stack cartons on pallets so that they are stable and flush on all sides. Brick stacking, with heaviest items on the bottom, is recommended.
- Do not let cartons overhang the edges of pallets (pictured below). If a single, large item has any overhang on a standard 40" x 48"/1m x 1.25m pallet, use a pallet size and type that is suitable for the item with no overhang and 5" maximum under hang on any one side.

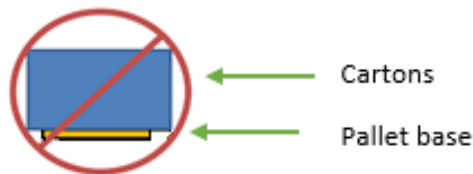

## Pallet Height

- **Stackable** – Pallets should be built 49" tall (44" of inventory + 5" of pallet height) with solid, flat tops that can be stacked for best truck utilization.
- **Non-Stackable** - If inventory cannot be handled with fork lift the maximum pallet height is 72".

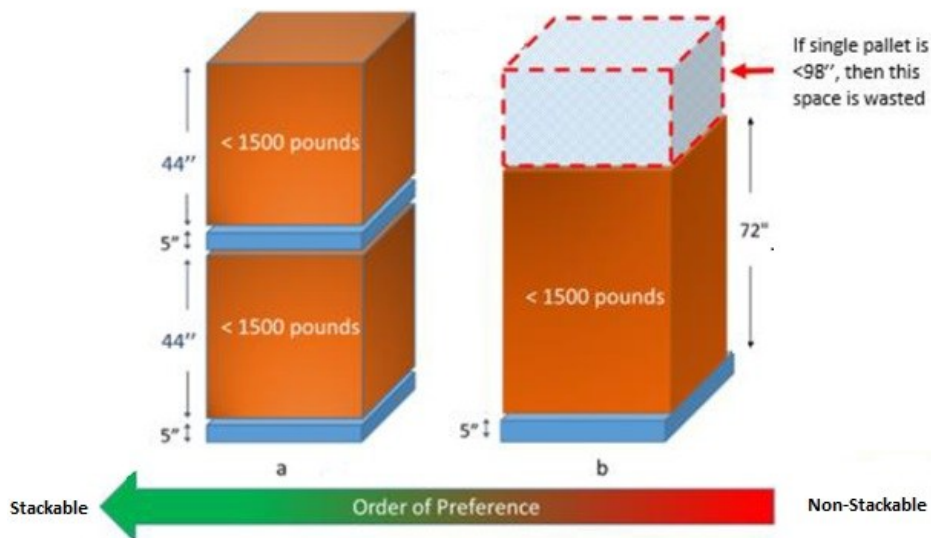

## SECTION 14: Loading Requirements

### Loading Shipments

The following loading requirements ensure that shipments are not damaged during transit and can be easily unloaded. Under all circumstances, loading must be completed in consultation with the carrier and any conflicting carrier instruction will supersede these guidelines.

### Pallet Loading

Arrange double stacked pallets so that both pallets are accessible by a forklift from the same side. Load bars, tension straps, air pillows, and/or diamond corrugated shims must be used to secure any double stacked pallet that may shift in transit or has a large void of space to the pallet's front, rear, or sides. Load bars or tension straps must also be used to secure the final pallets placed on a trailer in order to prevent freight from falling when doors are opened. Tension straps must not be hanging free and must be secured if not used.

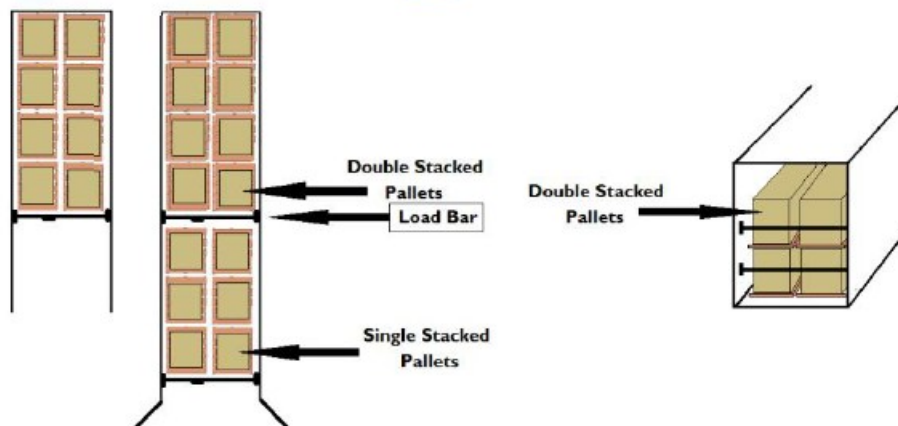

- Pallet loading for truckload (TL) shipments should use a “turned” configuration. This is two rows of pallets with the 48” dimension running on the width of the trailer and the 40” dimension running along the length dimension (see example below). This provides the best overall mix of utilization and load stability and provides space for 26 (single stacked) or 52 (double stacked) pallets. Straight or pinwheeled pallet arrangements, while allowed, may not allow you to fit all your freight on the trailer. Pallet loading for less than truckload (LTL) shipments should load pallets with pallet level labels facing the trailer’s doors.
- All trailers must have adequate strength cardboard placed against the cargo and secured in place using load bars/straps to prevent carton contact with the rear doors. 6" at the back of the trailer must be maintained to allow space for the dock plate to be engaged. It is the shipper and the carrier’s responsibility to ensure that shipments are loaded into a trailer in a balanced manner that prevents the load from shifting during transit or unloading. Products must be shrink wrapped together to prevent insecure loading.

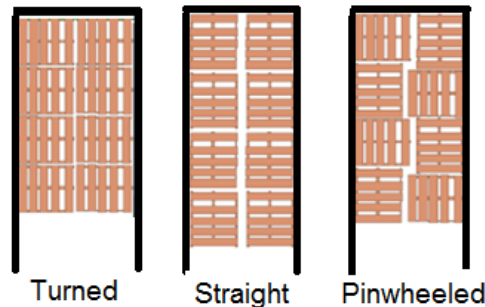

### Floor-Loading

- Palletize all shipments as much as possible to ensure earlier delivery appointments. Trailers loaded without the use of pallets are referred to as being ‘floor loaded’.
- Floor loaded shipments requiring extensive handling may be refused for safety reasons (i.e. boxes greater than 50.0 pounds). Zappos considers floor loading to be loose, stacked cartons, which are under 50.0 pounds in weight that will be unloaded by hand. Any additional charges assessed would vary based on the extra labor required, which can vary significantly from shipment to shipment. Parcel shipments are allowed to be greater than 50 lbs. if there is one unit per box. Apply a load strap or a load bar at the end of the trailer to provide an additional layer of load security.
- Stack cartons into columns in an alternating pattern to provide stability (T-Stacked). Cartons must not be bundled together with any kind of straps, zip ties, tape, etc.
- Only floor-load freight into containers that are at least 96”/ 2.5m tall.
- When loading the trailer, maintain stability between cartons stacks and container walls. Cartons must never be forced into a trailer into spaces that are smaller than the box size to prevent difficulty during the unload process.
- All shipments must be properly secured using load bars/straps. It is the shipper’s and the carrier’s responsibility to ensure that shipments are loaded into a trailer in a manner that prevents the load from shifting during transit.



*Example of floor loaded product correctly staged in a container*

## SECTION 15: International Shipments

Vendors fulfilling out of international facilities must first contact the International Inbound Transportation Services team at [zappos-Intltraffic@amazon.com](mailto:zappos-Intltraffic@amazon.com) prior to shipping. We would like to ensure that we handle your shipment accordingly and provide you with our **International Routing Request Form**. Mandatory documents listed in this section and the International Routing Request Form must be emailed to [zappos-Intltraffic@amazon.com](mailto:zappos-Intltraffic@amazon.com) prior to shipping each shipment.

### Information to be included on our International Routing Request Form:

- Valid Zappos Purchase Order Number (1-22 alphanumeric characters)
- Total number of cartons
- Total pairs or numbers of product (List units/pairs for each PO)
- Total weight in pounds (lbs.)
- Formula for cubic feet:  $(L'' \times W'' \times H'') / 1728 = \text{cube per carton}$  then take the cube per carton x number of cartons = total cubic feet
- The origination address and shipping hours of the shipment (e.g., Vendor warehouse)
- Origin contact person with email address, phone and fax number
- Indicate what type of product will be in the shipment (e.g., footwear, bags, apparel, etc.)

### Mandatory documents to be submitted along with the International Routing Request Form:

- Commercial Invoice (One PO Number per invoice)
- Packing List
- Interim Footwear Invoice, Product Detail Invoice, or HTS Code for each style (i.e. Footwear)
- Certificate of Origin

### GENERAL CERTIFICATES OF CONFORMITY MAY BE REQUIRED WITH YOUR SHIPMENT.

International shipments must list our company's name and zone number as the "Ship To/Deliver To" on the commercial invoice, packing list, and shipping carton label. To obtain the correct ship to address, email [zappos-Intltraffic@amazon.com](mailto:zappos-Intltraffic@amazon.com).

International shipments must list the following address as the "Buyer/Bill To/Invoice To" on the commercial invoice and packing list:

**Zappos.com LLC**  
400 E. Stewart Avenue  
Las Vegas, NV 89101 U.S.A.

**Carrier's Instructions:** All shipping instructions given by the carrier must be followed. Any additional freight charges incurred due to non-compliance with carrier shipping instructions (including 3rd party FCs, warehouses, or suppliers of brands) will be passed on to the Vendor. Any international shipments that need to be returned due to compliance or receiving issues, will be completed by the Vendor at the Vendor's expense.

## SECTION 16: Vendor Compliance & Scorecard

### Vendor Compliance

In an effort to help our Vendors meet operational expectations, Zappos collects and reviews Vendor operational data on a continual basis. We use this data to identify and address non-compliance in all areas of Vendor operations. Depending on the severity of non-compliance, various Zappos teams may initiate communication with Vendors to help bring awareness and a resolution to the situation. Vendors may receive a one-time contact regarding an isolated incident or may have ongoing communication with a Zappos compliance representative in order to rectify any problems.

Whenever necessary, Zappos may return merchandise at the Vendor's expense as a result of Vendor non-compliance. To help ensure continuous levels of quality, it is necessary to communicate to your Zappos buyer or the applicable Zappos operations team (page 4) well in advance of any circumstances that may compromise or interrupt service.

### Vendor Scorecard

Zappos generates a monthly Vendor Scorecard to all active suppliers. The goal of the scorecard is to provide visibility and accountability to our Vendor partners. The scorecard displays performance metrics related to EDI communications, fulfillment of Purchase Orders, and adherence shipment guidelines.

Scorecards are available within our Vendor Portal, Zapporo, to view at any time. Scorecard data is uploaded on the 15th of each month. It includes the Vendor performance data for the previous completed month and a historical view of previous months to review trends over time.

The Zappos compliance team will contact any Vendors who have continuous or high volume issues captured on the scorecard. Contacts of non-compliance relate to EDI communications, low fill rate percentages, multiple dispatches on a single PO, etc.

For more information regarding the scorecard, please review our Vendor Scorecard Guide located on the [Vendor Resources](#) site.

If you have any additional questions, would like to request access to your scorecard, or need to update your scorecard contacts, please email [zappos-vendorsupport@amazon.com](mailto:zappos-vendorsupport@amazon.com).

## SECTION 17: Zappos Vendor Returns / Inventory Removals

When a Zappos buyer and vendor agree to return units from our current inventory to the vendor, a removal order is processed internally by your Zappos buyer. This section explains what to expect from Zappos FCs when inventory is shipped back to the vendor. Please note we cannot make any special requests that lie outside of our removal, packing, and shipping processes.

### PICKING AND PACKING AT THE FCs

Zappos inventory is housed in 40+ FCs. A removal order can have inventory in various locations, thus creating separate removal orders for each FC that has inventory. Our FCs have 14 days to pull, pack, and ship all removals. Any delays due to unforeseen circumstances (FC staffing issues, peak holiday seasons, FC closures, pandemics, etc.) will be communicated to the Zappos buyer and will include an estimated time of completion.

Zappos will not remove any external labels/stickers (LPN or ASIN stickers) that have been placed on the item's packaging. Removal orders will not include individual packing slips or a master packing list. Shipments cannot be packed by style, color, size, etc. Upon request, an item breakdown can be provided to the Zappos buyer after the removal has shipped.

### SHIPPING

Fulfillment centers will begin to ship removals when enough inventory is pulled to qualify for a single shipment, even if there is still more inventory to remove. Shipments from multiple locations will not be combined. Depending on quantity and location, removals orders can be split into multiple shipments and assigned to multiple carriers, resulting in several tracking numbers and delivery dates. Once available, the Zappos buyer will receive tracking numbers for all shipments and they can be sent to the vendor upon request.

Orders will ship via small parcel and/or Less-than-Truckload (LTL) shipments. Zappos cannot designate specific carriers as they are assigned using an automated system at the time the removal is processed. If a removal order qualifies for an LTL shipment, the cartons will be palletized and delivered by a Zappos partnered freight company (ArcBest, YRC/RDWY, Estes). Small parcel shipping times should not exceed 7 to 10 business days. LTL shipping can take multiple weeks and vary depending on the delivery location distance. Zappos will communicate with the carriers about delayed shipments to remediate or expedite, but Zappos cannot control the carrier's operations.

The shipping labels or Bill of Ladings (BOLs) will indicate Amazon as the shipper. The vendor's address line will specify that this is a Zappos return. The Vendor RA number will only be listed on the Zappos call to attention (Example: **ATTN: ZAPPOS RA# XXXXXXX**).

**Important: By agreeing to a removal order, you agree to receive at your designated ship-to address all units that you have ordered to be removed. After it's submitted and your removal order is ready to ship, the carrier will attempt to contact your designated point-of-contact at your ship-to address to arrange a delivery time. If (1) the carrier is unable to arrange a delivery time for these units with your designated point-of-contact (for example, because they cannot be contacted at the telephone number provided in your removal order); or (2) your designated point-of-contact is unavailable or refuses to receive these units at the delivery time arranged with the carrier, we will assume that your designated ship-to-address is incorrect. These units will be deemed abandoned, and we may dispose of them immediately, at your cost, without reimbursement to you, and without additional notice to you.**

### VENDOR ARRIVAL

Upon receipt of the return, report any of the following issues to your Zappos buyer:

- Any items received in a gaylord container rather than shipping cartons.
- Any inventory that is incorrect or belonging to a different Vendor. (Return shipping labels and instructions will be provided by Zappos.)
- Items with excessive damage.
  - Please note: Packaging may experience some normal wear and tear due to shipping and handling to customers/vendor, extensive shelf life, FC movements, etc.

**If you have further questions regarding Vendor Removals>Returns, please contact your Zappos buyer directly.**

## SECTION 18: Accounts Payable

**Invoicing:** Invoices can only be submitted and processed via EDI. An EDI invoice must be submitted for products shipped pursuant to a Purchase Order, and contain the total items confirmed in the ASN. Vendor must issue a unique invoice number for each PO and issue only one invoice per PO.

The UPCs on the 810-Invoice must match the UPCs on the PO. Any additional UPCs included on the Invoice will delay payment, pending the Buyer's review.

**Price and Terms:** Our Purchase Order will control pricing and terms; we can reject any inconsistent terms on the Vendor's invoice. Disputes on pricing and terms are resolved by the Brand Representative and the Zappos buyer. The Zappos buyer will contact the Zappos Accounts Payable department if adjustments are to be made.

Note: The date used to determine the due date for all invoices will be based on the day Zappos receives a compliant, successful EDI transmission and not the date listed on the document. For example, if an invoice has a document date of 7/1/25 but is successfully submitted via EDI on 7/15/25, the invoice terms will begin on 7/15/25.

**Credit Memos:** Provide Zappos with a copy of any credit memo issued by the Vendor to Zappos.

**Credit Memos must be submitted to [zappos-apretail@amazon.com](mailto:zappos-apretail@amazon.com).**

**Monthly Statements:** Provide monthly statements of all open items on our account. Indicate the appropriate Zappos Purchase Order Number in addition to your invoice number. All invoice numbers on the statement should match the EDI invoice numbers submitted for the PO. Due to volume, invoice status and chargebacks will be addressed at the time your statement is reconciled. Outside of our monthly statement, you may view the invoice status in our self-service Vendor Accounting Portal, Taulia.

**Taulia:** Taulia is our self-service Vendor Accounting Portal. Vendors can sign up and view invoices, payment information and request early payment on approved invoices using the Dynamic Discount feature. For access to or login issues with Taulia please contact [zappos-apretail@amazon.com](mailto:zappos-apretail@amazon.com).

### Dispute Information

Zappos allows disputes for Vendor compliance claims under the following conditions:

- The dispute must be submitted through your assigned Zappos Accounts Payable representative that is responsible for managing your account.
- The dispute must be submitted within a period of 120 days following the claim's transmission date.

### Vendor Dispute Requirements

- Valid reason for all disputes, with an itemized list of disputed amount.
- Valid documentation including, without limitation, signed BOL/POD showing invoiced items shipped in full.
- Pertinent e-mail correspondence showing the Zappos Accounts Payable representative has acknowledged the dispute and confirmed an investigation has commenced.
- Once the 120-day dispute window has expired, Zappos will not honor the dispute, unless it is already in process.

**For questions about invoicing and disputes contact the Zappos Accounts Payable Team at [zappos-apretail@amazon.com](mailto:zappos-apretail@amazon.com).**

### Zappos.com LLC

Attn: Accounts Payable

PO Box 7469

Las Vegas, NV 89125-7469 U.S.A

## Appendix: Summary of Major Changes

### 1. Update—05/2025—Vendor Guide

- Zappos contact email addresses throughout the Vendor Guide.

### 2. Update—10/2025—Section 2: Electronic Data Interchange—Page 6

- Added ZAP1 location to Fulfillment Center (FC) addresses.

### 3. Update—05/2026—Section 2: Electronic Data Interchange—Page 6

- Removed ZAP2 from the Fulfillment Center (FC) list and added PSC2, PPO4, ABQ2, POC3, RYY2, and HEA2.

# **Zappos**

## **Routing Request Portal Instructions**

**2026 Version**

# TABLE OF CONTENTS:

## Routing Request Portal Instructions

<b>Section 1: Purpose</b>	<b>41</b>
<b>Section 2: Getting Started</b>	<b>41-44</b>
Login Method	42
Password Reset	43-44
<b>Section 3: How Do I Create A Routing Request</b>	<b>45</b>
<b>Section 4: Routing Request Page Overview</b>	<b>45</b>
<b>Section 5: Routing Statuses</b>	<b>46</b>
<b>Section 6: Address and Contact Information</b>	<b>47</b>
<b>Section 7: Purchase Order Validations</b>	<b>48</b>
<b>Section 8: Error Warnings</b>	<b>49</b>
<b>Section 9: Quick Recap</b>	<b>50</b>
<b>Section 10: FAQs</b>	<b>51-52</b>

## SECTION 1: Purpose

The purpose of this document is to:

- Introduce and help you get familiar with the Zappos Routing Request Portal.
- Provide a reference document that illustrates how to access and navigate through the Zappos Routing Request Portal.

What will I use the Routing Portal for?

- Submit Routing Requests for new shipments.
- Save shipments you are working on but not ready to submit.
- Submit additional Purchase Orders to “approved” open shipments.
- View current shipment status.

## SECTION 2: Getting Started

**STEP 1:** Please email the Zappos Inbound Transportation Services Team at [zappos-traffic@amazon.com](mailto:zappos-traffic@amazon.com) with the email address of the person who will be primarily responsible for routing your shipments. Please also include a list of PO Numbers that you either will be requesting routing on, or you have requested routing on in the past. This information allows us to associate this person as an authorized shipping contact for each of your brands within our system.

**STEP 2:** Wait for [zappos-traffic@amazon.com](mailto:zappos-traffic@amazon.com) to verify Purchase Order data, and authorize setup of supplier and Fulfillment Center contact relationship in our system.

You will receive an emailed response back from [zappos-traffic@amazon.com](mailto:zappos-traffic@amazon.com) with instructions on how to complete the setup process, and links to the portal site and other cool stuff.

**IMPORTANT:** You **must be listed** as the authorized Fulfillment Center contact for each supplier name as it appears on the Zappos Purchase Order to be granted access to the Zappos Routing Request Portal.

**Step 3:** The Zappos Routing Request Portal system is a web accessible application. Use an internet browser to access the system login screen.

## LOGIN METHOD

Go directly to the login screen by using the Zapporo (Zappos Purchase Order System) URL <https://zapporo.zappos.com/>.

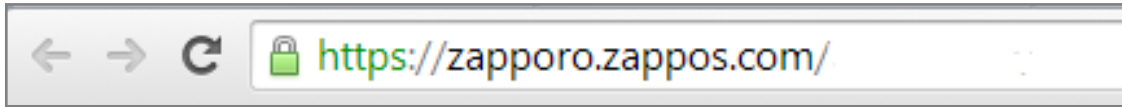

*Tip: Bookmark this page for future visits.*

## LOGIN SCREEN

At the login screen, type in the username and password and click 'Login' to enter the Routing Request Dashboard.

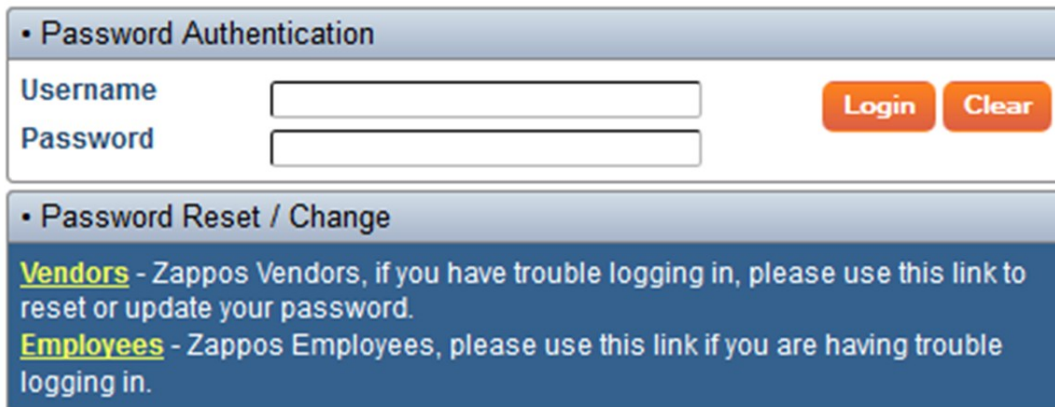
A screenshot of the login interface. The top section is titled "Password Authentication" and contains two input fields: "Username" and "Password". To the right of these fields are two orange buttons labeled "Login" and "Clear". Below this is a section titled "Password Reset / Change" with a dark blue background. It contains two links: "[Vendors](#) - Zappos Vendors, if you have trouble logging in, please use this link to reset or update your password." and "[Employees](#) - Zappos Employees, please use this link if you are having trouble logging in."

*Contact: Please reach out to [zappos-traffic@amazon.com](mailto:zappos-traffic@amazon.com) for login credentials.*

# PASSWORD RESET

Occasionally passwords are forgotten. Here are 4 easy steps to reset a Zappos Routing Request Portal password.

**1** Click the 'Vendors' link.

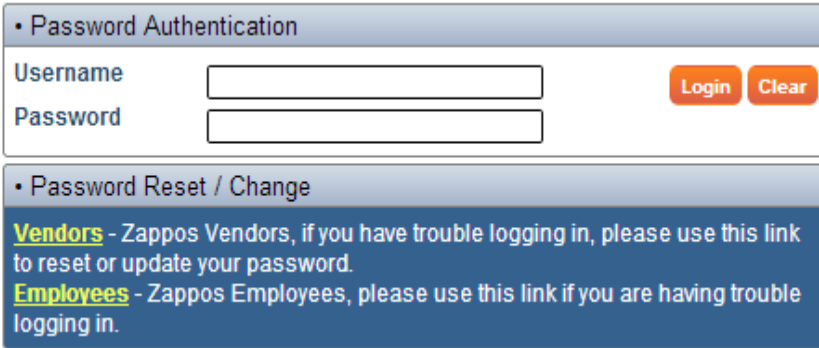

The screenshot shows a login form with fields for 'Username' and 'Password', and buttons for 'Login' and 'Clear'. Below the form is a section titled 'Password Reset / Change' with two links: 'Vendors' and 'Employees'. An orange arrow points to the 'Vendors' link.

**2** Type in email address and click 'Request Reset'.

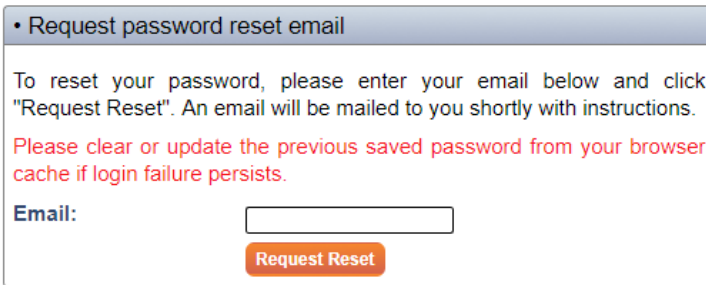

The screenshot shows a form titled 'Request password reset email'. It contains instructions: 'To reset your password, please enter your email below and click "Request Reset". An email will be mailed to you shortly with instructions. Please clear or update the previous saved password from your browser cache if login failure persists.' There is an 'Email:' input field and a 'Request Reset' button. An orange arrow points to the 'Request Reset' button.

You will receive the below message once you request the password reset.

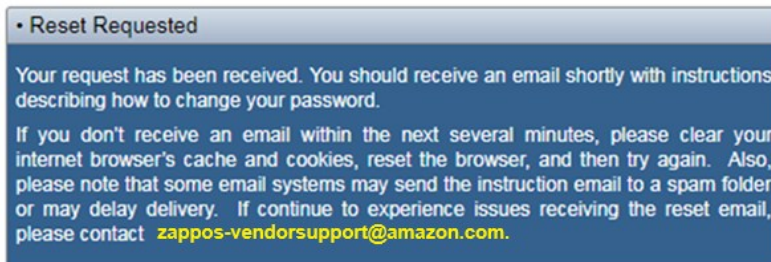

The screenshot shows a message titled 'Reset Requested'. The text reads: 'Your request has been received. You should receive an email shortly with instructions describing how to change your password. If you don't receive an email within the next several minutes, please clear your internet browser's cache and cookies, reset the browser, and then try again. Also, please note that some email systems may send the instruction email to a spam folder or may delay delivery. If continue to experience issues receiving the reset email, please contact [zappos-vendorsupport@amazon.com](mailto:zappos-vendorsupport@amazon.com).'

**3** Click the password reset link once the Zappos email is received.

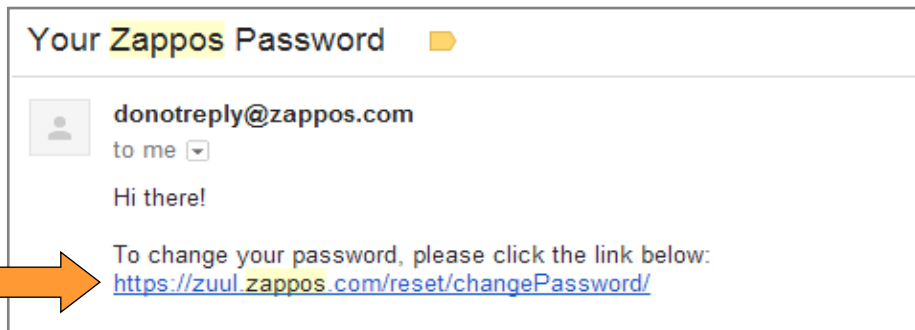

The screenshot shows an email from 'donotreply@zappos.com' with the subject 'Your Zappos Password'. The body of the email says: 'Hi there! To change your password, please click the link below: <https://zuul.zappos.com/reset/changePassword/>'. An orange arrow points to the link.

*Note: The password reset link expires after 24 hours.*



*Tip: Check junk/spam folders if the email does not show up within an hour. If you have not received an email after an hour, please contact [zappos-vendorsupport@amazon.com](mailto:zappos-vendorsupport@amazon.com).*

4

Enter a new password and click 'Update Password' to submit.

*You are using the Vendor Password Reset Tool*

• Choose your new password

Password:

Confirm Password:



• Password Requirements

- The password must not contain all or part of the username.
- The password must be at least 12 characters long.
- The password must also contain characters from all of the following four categories:
  - Latin uppercase letters (A through Z)
  - Latin lowercase letters (a through z)
  - Base 10 digits (0 through 9)
  - Non-alphanumeric characters such as: (!), (\$), (#), or (%)

5

Once you have updated your password, use the link below to log into the portal.

• Password Changed

Your password has been changed. Please [Click Here](#) to log in with your new password.

## SECTION 3: How To Create A Routing Request

After logging into the system the Routing Request dashboard will appear. Click the “Create Routing Request” link to proceed.

The screenshot shows the Zappos Dashboard interface. At the top, it says "Zappos Dashboard" with "UI Version: 10.24.3" and "Service Version: 10.24.0". The user is logged in as "Fulfillment Vendor". On the left, a navigation menu is visible with "Create Routing Request" highlighted. A yellow arrow points to this link. The main content area displays a "Welcome to Zapporo!" message and the Zappos logo. Below this, there are "Vendor Resources" including links for "Resource", "EDI Guidelines", "Zappos Vendor Guide", "Zapporo Quick Reference Manual", and "Routing Portal Instruction".

## SECTION 4: Routing Request Page Overview

The screenshot shows the "Routing Request View" page. It includes a navigation menu on the left with "Create Routing Request" highlighted. The main form is divided into several sections:

- 1. Routing Request Information:** Shows "Routing Status" (Initiated), "Ship To" (with a note to choose PO), "Created Date", "Created By" (Vendor), "Creator ID", and "Direct Delivered" (checkbox). Buttons for "Save Only", "Submit", and "Upload" are present.
- 2. Addresses and Contact Information:** Includes "Pick Up Address" (with "New Address" and "Use Saved Address" options), "Additional Shipping Info" (Hours, Ready Date, Appt Needed, Comments), and "Shipper Contact Person, Telephone, Fax & E-mail Address" (Name, Phone, Fax, Email, CC Email). A "Clear" button is also visible.
- 3. Ready Date:** A text input field for the ready date.
- 4. PO Shipments:** A table with columns for PO #, Cases, Pairs/Units, Weight (lbs), Cubic Ft, Product Type, Start Ship, and Cancel Ship. The "Total POs" is 0.

1. Routing Request Information showing routing status.
2. Addresses and Contact Information (must include the address of the physical shipping location).
3. Ready Date must be tomorrow’s date or later. Ready Date must fall within the ship window of all requested Purchase Orders.
4. Purchase Order Data Entry Fields.

## SECTION 5: Routing Statuses

• Routing Request View

Routing Status	Initiated	Ship To	Zappos Merchandising, Inc. <small>(choose PO in order to determine warehouse location)</small>
Created Date			
Created By	Vendor		
Direct Delivered	<input type="checkbox"/>		

Save Only
Submit
Upload

Routing Status Explained	
Initiated	Routing Request has been started but has not been submitted to Zappos for approval.
Submitted	Routing Request was successfully sent to the Zappos Inbound Logistics Team.
Pending Approval	Routing Request is being reviewed by the Zappos inbound Logistics Team.
Approved	Routing Request has been assigned a dispatch number, and shipping instructions will be emailed to email contacts listed.
Carrier Assigned	A carrier has been assigned to pick up your shipment. An email with details will follow shortly.
Picked Up	Shipment has been retrieved by carrier.
Delivered	Shipment has arrived to the Fulfillment Center.
Field Descriptions	
Created Date	The date that the Routing Request was originally submitted.
Created By	Lists approved user who is logged into the system.
Direct Delivered	Check this box only when the Routing Request will be a supplier pre-paid shipment via the carrier of their choice. See pages 29-30 of the Zappos Vendor Guide for more details.
Ship To	Destination location as currently listed on the Purchase Order.

**What is the difference between the “Save Only” and “Submit” buttons?**



**Save Only:**

Use this button to save a new routing that is in a working status and **not** ready to submit to Zappos for approval.

**Submit:**

Use this button to submit this request to Zappos. Once submitted, no changes can be made until Zappos Inbound Logistics team has reviewed for approval.

## SECTION 6: Address and Contact Information

You can add a new Pick Up Address or Click on “Use Saved Address” for any previously entered addresses.

The image shows two screenshots of a web interface for managing addresses. The top screenshot displays a dropdown menu for 'Addresses and Contact Information' with a sub-section for 'Pick Up Address'. Below this, there are two buttons: 'New Address' (with a plus icon) and 'Use Saved Address' (with a plus icon). The bottom screenshot shows the 'New Address' form. It includes a 'Supplier' field, an 'Address' field, a 'City' field, a 'Country' dropdown menu (with '--- Choose One ---' selected), and a 'Zip' field. At the bottom of the form, there is a checkbox labeled 'Save address for future routing requests.' and a red 'Cancel' button with an 'X' icon.

All information is to be filled in appropriately and will be needed to successfully submit a shipment for approval.

Field	Description of Field	Action by Supplier
Supplier	Supplier who is shipping product	Must fill in
Address	Physical shipping location where product is to be picked up	Must fill in
City	City of physical shipping location	Must fill in
State	State of physical shipping location	Must fill in
Zip	Zip Code of physical shipping location	Must fill in
Hours	Operational hours that carrier can pick up shipment	Must fill in
Ready Date	The date product will be ready for a carrier to pick up	Must fill in
Comments	Special instructions to carrier <u>or</u> Zappos on shipment	Optional fill in
Name	Contact name (will always be secured logged in user)	Must fill in
Phone	Phone number to contact in reference to shipment	Must fill in
Fax	Fax number	Optional fill in
Email	Email address of the main point of contact for shipment information.	Must fill in
CC Email	Carbon Copy – add contacts to be included on e-mail distribution	Optional fill in

## SECTION 7: Purchase Order Validations

PO #	Cases	Pairs/Units	Weight (lbs)	Cubic Ft.	Product Type	Start Ship	Cancel Ship	
3844599		672			Accessories	11/01/2018	11/07/2018	Remove
Total POs: 1		0	0	0				

Save Only Submit

Below is a detailed explanation of the required field and validations that occur.

Field	Description of Field	Action by Supplier	Routing Portal Validation
PO#	Zappos Purchase Order Number (Example EXNULAO1111123)  NOTE: "EXNULAO" is an alphabetic prefix. We do not use leading zeros in our Purchase Order Numbers.	Must fill in	1) User is associated to this Purchase Order 2) Ready to ship status is "yes" 4) Valid Purchase Order number
Cases	Amount of master cartons on Purchase Order	Must fill in	N/A
Pairs /Units	Total amount of units being routed to ship per Purchase Order	Must fill in	Remaining amount of units available to ship
Weight	Total Combined Weight of all cartons per Purchase Order	Must fill in	N/A
Cubic Foot	Total Cubic feet of all cartons per Purchase Order	Must fill in	Total cubic feet does not exceed 3300 ft <sup>3</sup> .
Product Type	Product type on Purchase Order	Auto filled in	N/A
Start Ship	Start ship date of Purchase Order	Auto Filled in based on Purchase Order Number	Current Purchase Order data
Cancel Ship	Last ship date of Purchase Order	Auto Filled in based on Purchase Order Number	Current Purchase Order data

## SECTION 8: Error Warnings

If this warning sign appears, there is an issue that needs to be addressed prior to submitting the Routing Request.

Example:



One or more of the below reasons may be the issue:

1. Your username may not be listed as the Zappos Fulfillment Contact for the brand associated with this Purchase Order Number. Please email [zappos-traffic@amazon.com](mailto:zappos-traffic@amazon.com) for assistance. Please be sure to include the Purchase Order Number, the username you are logged in with and a screen shot of the error if possible.
2. The Purchase Order Number does not exist in the Zappos system. Please double check your Purchase Order Number for accuracy. Please email [zappos-traffic@amazon.com](mailto:zappos-traffic@amazon.com) for assistance. Please be sure to include the Purchase Order Number, the username you are logged in with and a screen shot of the error if possible.
3. The Purchase Order has an open change request that needs to be addressed by the buyer. Please ask your brand rep to reach out to their buyer to resolve. Once resolved, the error message will no longer appear and you can submit the Routing Request.
4. Requested quantities are more than what our system has open and available to route.

If this is your 1st time routing this Purchase Orders please ensure you are routing against the most up to date open quantities for this Purchase Order.

If this is NOT your 1st time routing this Purchase Order please try the following:

1. Check your open units against the most up to date open quantities for this Purchase Order.
2. Check the amount of units that were routed previously.
3. If there is a discrepancy with what was routed previously versus the amount actually shipped, email the accurate and revised totals for each shipment to [zappos-traffic@amazon.com](mailto:zappos-traffic@amazon.com).

PO #	Cases	Pairs/Units	Weight (lbs)	Cubic Ft.	Product Type	Start Ship	Cancel Ship	
4026663	<input type="checkbox"/>	0	<input type="checkbox"/>	<input type="checkbox"/>	Footwear	11/23/2018	11/30/2018	Remove
	<input type="checkbox"/>							
Total POs: 1		0	3	0				

Buttons: Save Only Submit

# SECTION 9: Quick Recap

Primary Role: Fulfillment Vendor Zappos Dashboard UI Version: 8.5.0  
Services Version: 8.5.0 Logged in as Vendor | [Logout](#)

---

**• Fulfillment Vendor**

- Home
- Routing Requests
  - [Create Routing Request](#)
  - [Routing Request Search](#)

**• Routing Request View**

Routing Status: Initiated Ship To: (choose PO in order to determine warehouse location)

Created Date: \_\_\_\_\_  
Created By: Vendor \_\_\_\_\_  
Creator ID: \_\_\_\_\_  
Direct Delivered:

[Save Only](#) [Submit](#) [Upload](#)

---

**• Addresses and Contact Information**

**Pick Up Address** **Shipper Contact Person, Telephone, Fax & E-mail Address**

[New Address](#) [Use Saved Address](#)

**Additional Shipping Info**

Hours: \_\_\_\_\_  
Ready Date: \_\_\_\_\_   
Appt Needed:   
Comments:

Name: \_\_\_\_\_  
Phone: \_\_\_\_\_  
Fax: \_\_\_\_\_  
Email: \_\_\_\_\_  
CC Email: \_\_\_\_\_ [Clear](#)

---

**• PO Shipments**

PO #	Cases	Pairs/Units	Weight (lbs)	Cubic Ft.	Product Type	Start Ship	Cancel Ship
_____	<input type="text"/>	<input type="text"/>	<input type="text"/>	<input type="text"/>			
Total POs: 0	0	0	0	0			

[Save Only](#) [Submit](#)

1. Fill in all fields.
2. Review Section 8 for Error Warnings.
3. Create and submit.
4. Wait for approval or pending resolution emails from the Zappos Inbound Logistics Team.

## SECTION 10: FAQs

### 1. How will I know if my Routing Request was successfully sent?

- A green bar indicates that the routing was submitted successfully.

Example:

*Routing Request Created and Submitted*

**THIS DOES NOT INDICATE THAT THE SHIPMENT HAS BEEN APPROVED TO SHIP. IT ONLY INDICATES THAT IT WAS SUBMITTED FOR REVIEW AND FOR APPROVAL.**

• Routing Request Information			
Routing Request #	1201	Ship To	
Routing Status	Submitted		
Created Date	06/12/20 12:03:25 PM		
Created By	Test User		
			376 Zappos.com Blvd FTZ#029_Site 6 Shepherdsville, KY 40165 USA

*Routing Request Created and Submitted*

### 2. How will I know if my Routing Request was approved?

- Check the status (see section 5 of the Routing Request Portal Instructions for Routing Statuses).
- If approved, you will receive the dispatch reference number and further instruction via email.
- If there is a pending approval, you will receive an approval email shortly with further instructions.

### 3. How do I add additional units to a shipment?

STEP 1: Go to the last shipment created and check the status

STEP 2: Verify that it is in “Approved” status

STEP 3: Make changes and click “Save Changes and Submit”

STEP 4: Wait for approval

**DO NOT ADD UNITS TO A SHIPMENT UNLESS IT HAS BEEN APPROVED BY THE ZAPPOS IN-BOUND TRANSPORTATION SERVICES TEAM.**

#### 4. How will I know if my Routing Request was successfully sent?

- Click on the Routing Request Search link.

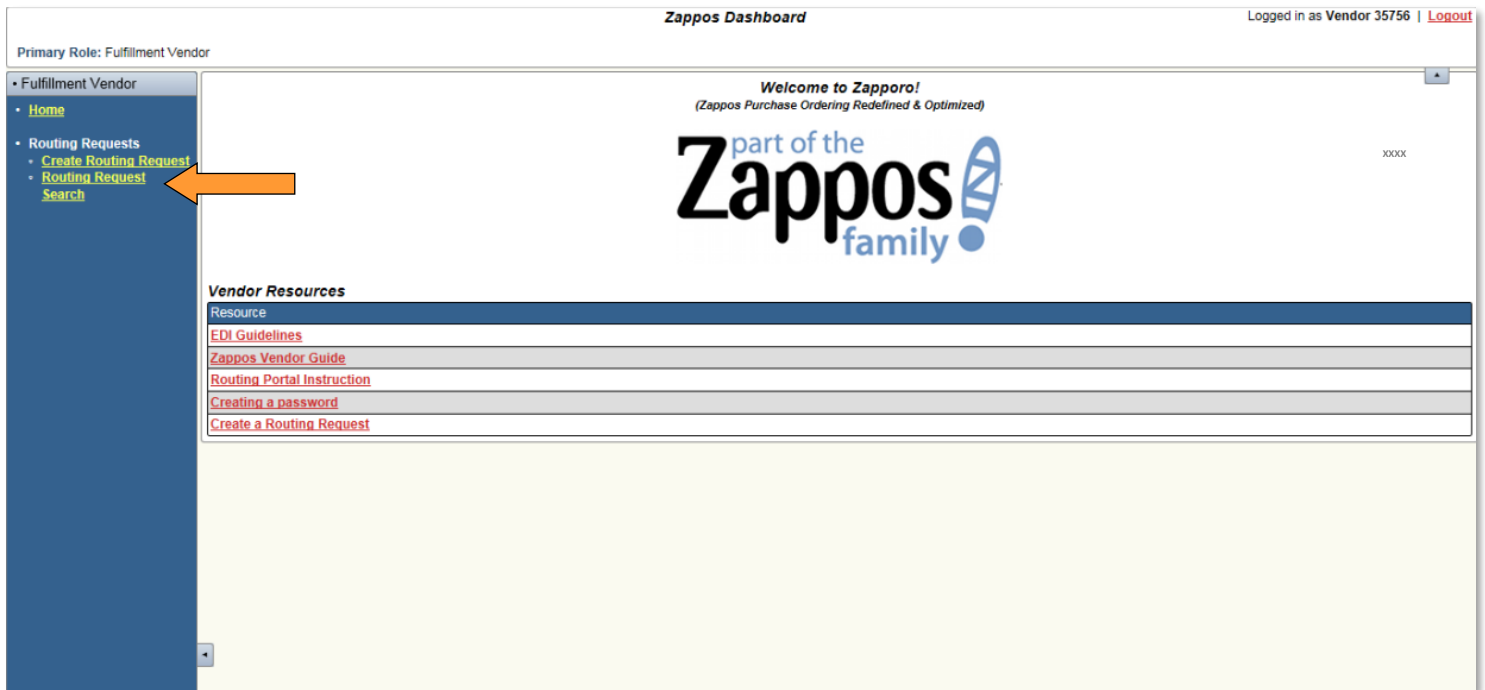

**NOTE:** Users can only search for routings that were created under their user log in.

#### Useful for:

- Searching for routings that are created but not submitted yet
- Checking the status of previous routings
- Making additions to routing that have not been picked up

Please email the Zappos Inbound Transportation Services Team at [zappos-traffic@amazon.com](mailto:zappos-traffic@amazon.com) with any questions or concerns in regards to the Routing Request Portal.